

Chameleon™ Discovery NX Laser Systems

Operator's Manual

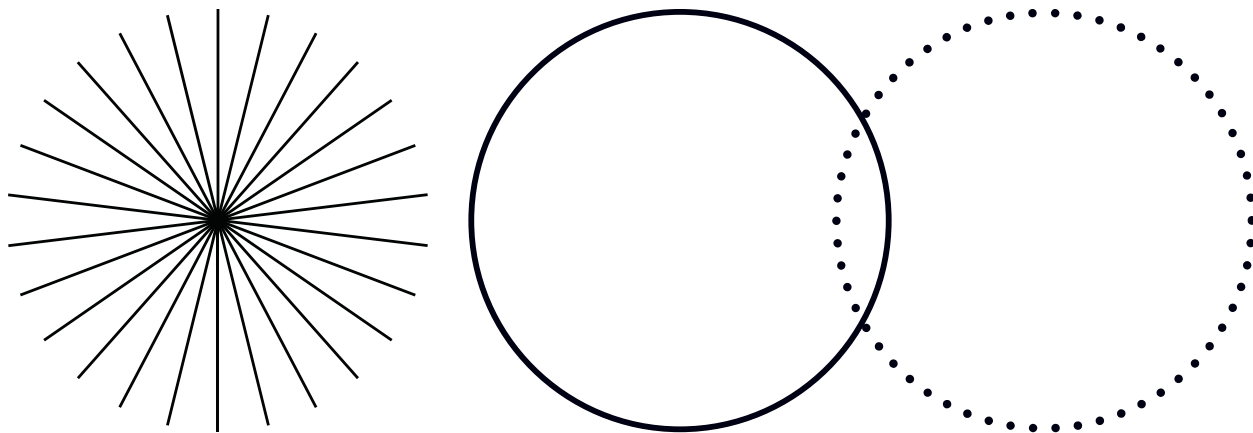

**Operator's Manual
Chameleon™ Discovery NX
Laser Systems**



Todd Campus, West of Scotland Science Park, Maryhill Road
Glasgow, G20 0XA, Scotland

This document is copyrighted with All Rights Reserved. Under copyright laws, this document must not be copied in full or in part, or reproduced by any other media, without the express written permission of Coherent, Inc. (Coherent). Permitted copies must have the same proprietary and copyright notices as were attached to the original. This exception does not permit copies—whether or not sold—to be made for others; however, all the material purchased can be sold, given, or loaned to another person. Under the law, “copying” includes translation into another language.

Coherent, the Coherent Logo, and the Chameleon Discovery NX are registered trademarks of Coherent, Inc. All other trademarks or registered trademarks are the property of their respective owners.

Patents referenced in this manual are active when the manual is printed (see last page for the date). You are advised to check if the patents are still active www.coherent.com/legal/patents.

Every effort was made to make sure that the data shown in this document is accurate. The information, figures, tables, specifications, part numbers, and schematics contained in this manual are subject to change without notice. Coherent makes no warranty or representation, either expressed or implied, related to this document. In no event will Coherent be liable for any direct, indirect, special, incidental, or consequential damages caused by any defects in its documentation.

Technical Support

In the U.S.:

Should you experience any difficulties with your laser or need any technical information, please go to our web site www.Coherent.com. Should you need further assistance, please contact Coherent Technical Support by e-mail customer.support@coherent.com or telephone, +1-734-456-3100. Please be prepared to supply the model and laser head serial number of your laser system, the description of the problem, and any attempted corrective steps to the Product Support Engineer responding to your request.

Telephone coverage is available Monday through Friday (except U.S. holidays and company shutdowns). Inquiries received outside of normal office hours will be captured by our automatic answering system and will be quickly returned the next business day.

Outside the U.S.:

If you are located outside the U.S., please visit www.Coherent.com for technical assistance, or contact your local Service Representative. Service Representative telephone numbers and addresses can be found on the Coherent web site.

Coherent provides telephone and web-based technical assistance as a service to its customers and assumes no liability for any injury or damage that can occur at the same time with such services. Under no conditions do these support services affect the terms of any warranty agreement between Coherent and the buyer. Operation of any Coherent laser with any of its interlocks defeated is always at the operator's own risk.

Table of Contents

1 Introduction	1
1.1 Signal Words and Symbols in this Manual.....	1
1.1.1 Signal Words	1
1.1.2 Symbols	2
1.2 Preface	3
1.3 Export Control Laws Compliance.....	3
1.4 The Operator’s Manual.....	4
1.4.1 Intended Audience.....	5
1.4.2 Availability and Use.....	5
1.4.3 Numbering of Sections, Pages and Instructions	5
1.4.4 Cited Standards.....	6
1.5 Laser Terminology.....	6
1.6 Units of Measurements	7
1.7 Feedback Regarding Documentation	7
1.7.1 Feedback Address	7
2 Laser Safety Table.....	9
3 Description and Specifications.....	11
3.1 System Description.....	11
3.2 Chameleon Discovery NX Laser Head	12
3.3 Power Supply.....	12
3.4 Miniature Recirculating Unit (MRU)	12
3.5 Closed Loop Chiller.....	12
3.6 Specifications	13
3.7 Environmental Requirements	13
3.8 System Dimensions & Weight	13
3.8.1 Laser Head Dimensions	14
3.8.1.1 Discovery NX Laser Head	14
3.8.1.2 Discovery NX TPC Laser Head	16
3.8.2 Chameleon Discovery NX Power Supply.....	17
3.8.3 Chiller.....	19
3.8.4 MRU X1.....	20

4 Installation	23
4.1 Receiving and Inspection	23
4.1.1 Lifting Handles (Removable)	24
4.2 Fuse Verification	24
4.3 Chiller Water Coolant	25
4.4 System Connections	25
4.5 External Interlock	27
5 Controls, Indicators, and Features	29
5.1 Controls and Indicators	29
5.1.1 Laser Head	29
5.1.1.1 Laser Head Feature, Controls and Indicators Description	31
5.1.2 Power Supply	31
5.1.2.1 Power Supply Feature, Controls and Indicators Description	33
6 Operation	35
6.1 Operating States	36
6.1.1 Turn-on (Cold Start)	36
6.1.2 Daily Turn-on (Warm Start)	37
6.2 System Turn-off	38
6.2.1 Turn-off (Daily Use)	38
6.2.2 Turn-off (Complete Shutdown)	38
7 External Computer Control	41
7.1 Chameleon Discovery NX Interface	41
7.1.1 Communication Syntax	41
7.1.1.1 ECHO Mode	42
7.1.1.2 PROMPT Mode	43
7.1.2 RS-232 Interface Connection	43
7.1.2.1 RS-232 Configuration	43
7.1.3 USB Interface Connection	43
7.1.3.1 USB Configuration	44
7.1.4 Instruction Set	44
7.1.4.1 Command Set	45
7.1.4.2 Query Set	47
8 TPC Modulator Control	51
8.1 Introduction	51
8.1.1 TPC Overview	51
8.1.2 Control Configuration	51
8.1.2.1 Laser Control	52

8.1.2.2 Direct USB (Legacy Mode).....	53
8.1.2.3 Direct RF	55
8.1.3 Power Control.....	55
8.1.3.1 Software Power Control	55
8.1.3.2 External Modulation.....	56
8.1.4 Calibration for Direct USB (Legacy Mode) Modulator Control	57
9 Troubleshooting.....	59
9.1 Troubleshooting Guide	59
9.1.1 No Laser Output.....	59
9.1.2 Beam Pointing Varies with Wavelength (TPC systems only)	60
9.1.3 Fault Conditions	60
9.1.3.1 External Interlock Condition	61
9.1.3.2 Any Other Fault	61
9.1.3.3 Contacting Coherent Service	61
10 Maintenance	63
10.1 Chiller Maintenance	63
10.1.1 Draining Chiller	63
10.1.2 Refill Chiller	64
11 Packing Procedure	67
11.1 Introduction	67
11.2 Chameleon Discovery Crate	68
11.3 Packaging the Discovery Laser Head	68
12 MRU X1	73
12.1 Description and Specifications.....	73
12.1.1 System Features	74
12.1.2 System Specifications.....	75
12.2 Safety	75
12.2.1 Chemical Safety	76
12.2.2 Operating Controls	76
12.2.3 Location of Safety Labels	76
12.2.4 Compliance with Government Requirements.....	79
12.3 Installation	79
12.3.1 Receiving and Inspection	79
12.3.2 19" Rack Mounting Brackets	79
12.3.3 External Connections	80
12.3.4 Air Connections	80
12.3.5 Interlock Connections.....	81

12.4 Controls and Indicators	84
12.4.1 Front Panel Indicator	85
12.4.1.1 Power LED	85
12.4.2 Rear Panel Controls and Indicators	85
12.4.2.1 Air In & Air Out Ports	85
12.4.2.2 Interlocks	86
12.4.2.3 Mains Power Input	86
12.5 Maintenance and Troubleshooting	87
12.5.1 Maintenance	87
12.5.1.1 Interlock Circuit Checkout	87
12.5.1.2 Drying Filter	88
12.5.1.2.1 Inspect/Change Drying Filter	88
12.5.1.3 HEPA Filter Replacement	90
12.5.1.4 Fuse Replacement	90
13 Calibration File Examples	91
13.1 Sample Calibration Files	91
13.1.1 Tunable RF Power vs Wavelength vs Transmission	91
13.1.2 Tunable Wavelength vs RF Frequency	92
13.1.3 Fixed RF Power vs Transmission	93
Appendix I: Laser Safety	95
I.1 Hazards	95
I.1.1 Optical Safety	96
I.1.1.1 Recommended Precautions and Guidelines	97
I.1.1.2 Laser Safety Eyewear	97
I.1.2 Electrical Safety	98
I.1.2.1 Recommended Precautions and Guidelines	98
I.2 Maximum Accessible Radiation Level	99
I.3 Safety Features and Compliance with Government Requirements	99
I.3.1 Laser Classification	100
I.3.2 Protective Housing	100
I.3.3 Remote Interlock Connector	100
I.3.4 Key Control	100
I.3.5 Laser Radiation Emission Indicators	101
I.3.6 Beam Attenuator	101
I.3.7 Operating Controls	101
I.3.8 Manual Reset Mechanism	101
I.4 Electromagnetic Compatibility	102
I.5 Environmental Compliance	102

I.5.1 RoHS Compliance	102
I.5.2 China-RoHS Compliance	102
I.5.3 EU REACH	103
I.5.4 Waste Electrical and Electronic Equipment (WEEE)	104
I.5.5 Battery Directive	104
I.5.6 Location of Safety Labels	104
I.6 Sources of Additional Information	111
I.6.1 Laser Safety Standard	111
I.6.2 Publications and Guidelines	111
Appendix II: Parts List	113
Appendix III: Accessories	115
III.1 Power Meters and Sensors	115
III.1.1 Coherent's Recommendation	115
Appendix IV: Warranty	117
IV.1 Responsibilities of the Buyer	117
IV.2 Limitations of Warranty	117
Glossary	119
Index	121

List of Illustrations

3-1. Chameleon Discovery NX Laser System	11
3-2. Discovery NX Head Dimensions	14
3-3. NX TPC Laser Head Dimensions	16
3-4. Power Supply Dimensions	17
3-5. SMC Rack Mount Chiller	19
3-6. MRU X1	20
4-1. Lifting Handles (Removable)	24
4-2. Chameleon Discovery NX NX Laser System Connections	26
4-3. Example External Interlock Circuit	28

5-1.	Laser Head - Features, Controls, and Indicators	29
5-2.	Power Supply - Features, Controls and Indicators	32
7-1.	RS-232 Pin Configuration	44
8-1.	Discovery NX TPC Connection Locations	52
10-1.	Chiller Drain.....	64
10-2.	Chiller Diagram	65
11-1.	Removable Lifting Handles.....	67
11-2.	Chameleon Discovery Crate.....	68
11-3.	Placing Laser Head on Trolley	69
11-4.	Covering the Laser Head	69
11-5.	Pushing the Laser Head Into the Crate	70
11-6.	Securing Clamps	71
11-7.	Fitting the Crate Lid.....	71
12-1.	Coherent MRU X1	73
12-2.	MRU X1 Labels.....	77
12-3.	Example Interlock Circuits	82
12-4.	MRU X1 Controls and Indicators.....	84
12-5.	Air Ports and Laser Interlocks (Back of Unit).....	86
12-6.	Mains Input Showing Fuse Access	87
12-7.	MRU X1 Internal Components	89
I-1.	Chameleon Discovery NX Laser Safety Features and Labels	105
III-1.	PM10-19C USB PN 1168344	116

List of Tables

2-1.	Laser Safety Reference Table	9
3-1.	Environmental Requirements	13
3-2.	System Dimensions and Weight	13
4-1.	Fuse Ratings	25
5-1.	Discovery NX (TPC) Laser Head - Features, Controls, and Indicators.....	31
5-2.	Discovery NX (TPC) Power Supply Controls, Indicators and Features	33
6-1.	Chameleon Discovery NX Operating States	36
7-1.	Response from Laser after Receiving Instruction	42
7-2.	RS-232 Port Description	43
7-3.	USB Port Description	44
7-4.	Chameleon Discovery NX Commands	45
7-5.	Chameleon Discovery Queries	47
8-1.	TPC Connection Specification and Description	52
8-2.	Laser Serial Commands for Modulator Control	53
8-3.	Port Description - AOM Driver	53
8-4.	RF Driver Commands List	54
8-5.	Modulation Configuration Set-Up	57
8-6.	AOM Calibration Parameters.....	58
9-1.	No Laser Output	59
9-2.	Beam Pointing Varies	60
12-1.	MRU X1 System Specifications.....	75
12-2.	MRU X1 Controls and Indicators.....	85
I-1.	China-RoHS Compliant Components.....	103
I-2.	Batteries Contained in this Product	104
II-1.	Parts List	113

This Page Intentionally Left Blank

1 Introduction

1.1 Signal Words and Symbols in this Manual

This documentation may contain sections in which particular hazards are defined or special attention is drawn to particular conditions. These sections are indicated with signal words in accordance with ANSI Z-535.6 and safety symbols (pictorial hazard alerts) in accordance with ANSI Z-535.3 and ISO 7010.

1.1.1 Signal Words

Four signal words are used in this documentation: **DANGER**, **WARNING**, **CAUTION** and **NOTICE**.

The signal words **DANGER**, **WARNING** and **CAUTION** designate the degree or level of hazard when there is the risk of injury:

DANGER!

Indicates a hazardous situation that, if not avoided, will result in death or serious injury. This signal word is to be limited to the most extreme situations.

WARNING!

Indicates a hazardous situation that, if not avoided, could result in death or serious injury.

CAUTION!

Indicates a hazardous situation that, if not avoided, could result in minor or moderate injury.

The signal word "**NOTICE**" is used when there is the risk of property damage:

NOTICE

Indicates information considered important, but not hazard- related.

Messages relating to hazards that could result in both personal injury and property damage are considered safety messages and not property damage messages.

1.1.2

Symbols

The signal words **DANGER**, **WARNING**, and **CAUTION** are always emphasized with a safety symbol that indicates a special hazard, regardless of the hazard level:



This symbol is intended to alert the operator to the presence of additional information.



This symbol is intended to alert the operator to the presence of important operating and maintenance instructions.



This symbol is intended to alert the operator to the danger of exposure to hazardous visible and invisible laser radiation.



This symbol is intended to alert the operator to the presence of dangerous voltages within the product enclosure that may be of sufficient magnitude to constitute a risk of electric shock.



This symbol is intended to alert the operator to the danger of Electro-Static Discharge (ESD) susceptibility.



This symbol is intended to alert the operator to the danger of crushing injury.



This symbol is intended to alert the operator to the danger of a lifting hazard.

1.2

Preface

This manual contains user information for the Chameleon Discovery NX



NOTICE

Read this manual carefully before operating the laser for the first time. Failure to follow the instructions and safety precautions in this manual can result in serious injury or death. Special attention must be given to the material in “Laser Safety” (p. 95), that describes the safety features built into the laser. Keep this manual with the product and in a safe location for future reference.



DANGER!

Use of controls or adjustments or performance of procedures other than those specified herein may result in hazardous radiation exposure.

1.3

Export Control Laws Compliance

It is the policy of Coherent to comply strictly with U.S. export control laws.

Export and re-export of lasers manufactured by Coherent are subject to U.S. Export Administration Regulations, which are administered by the Commerce Department. In addition, shipments of certain components are regulated by the State Department under the International Traffic in Arms Regulations.

The applicable restrictions vary depending on the specific product involved and its destination. In some cases, U.S. law requires that U.S. Government approval be obtained prior to resale, export or re-export of certain articles. When there is uncertainty about the obligations imposed by U.S. law, clarification must be obtained from Coherent or an appropriate U.S. Government agency.

Products manufactured in the European Union, Singapore, Malaysia, Thailand: These commodities, technology, or software are subject to local export regulations and local laws. Diversion contrary to local law is prohibited. The use, sale, re-export, or re-transfer directly or indirectly in any prohibited activities are strictly prohibited.

1.4 The Operator's Manual

This Operator Manual is designed to familiarize the user with the Chameleon Discovery NX system and its designated use. It contains important information on how to install, operate, and troubleshoot the laser system safely, properly, and most efficiently. Observing these instructions helps to avoid danger, reduce repair costs, and downtimes and increase the reliability and lifetime of the laser system.

Installation, deinstallation, servicing, and detailed troubleshooting are only to be performed by formally trained and instructed personnel. Consequently, these procedures are not contained in the Operator's Manual but in the separate Service Manual.

This Manual:

- describes the physical hazards related to the laser system, the means of protection against these hazards, and the safety features incorporated in the design of the laser system
- briefly describes the purpose and operation as well as the primary features, system elements, subsystems, and fundamental laser control routines of the laser system
- describes the fundamental operation of the laser system
- describes the maintenance procedures for the laser system which can be performed by the end user. This includes a time schedule for all periodic routine replacement procedures and a basic troubleshooting section.



The screenshots in this manual are only examples and may show configurations or parameter settings which do not apply to Discovery NX laser system. Changing parameter settings to correspond with screenshots may reduce laser performance or even damage the laser system!

1.4.1 Intended Audience

The Operator's Manual is intended for all persons that are to work on or with the laser system. It assumes that the reader has participated in an introductory training course which has taught them the safe operation of the laser system.

None of the procedures described in this manual requires the defeating of safety interlocks. Where specific training is required to perform procedures, this is clearly indicated at the beginning of the corresponding section.

1.4.2 Availability and Use

This Operator's Manual must always be available wherever the laser system is in use. Keep this manual in a safe location for future reference. It must be read and applied by any person in charge of carrying out work with and on the laser system, such as

- operation (including setting up, troubleshooting in the course of work, removal of production waste, care and disposal of consumables,
- service (maintenance, inspection, repair) and/or
- transport.

1.4.3 Numbering of Sections, Pages and Instructions

The sections are numbered continuously. The name of the section appears in the upper outside corner of every odd page. Each section ends with an even page number. Consequently, certain even pages at the ends of sections will be intentionally left blank.

The pages of this manual are numbered continuously by section. The page number appears in the bottom center of every page.

Each step within a procedure is sequentially numbered. Each procedure starts with the step number one.

1.4.4 Cited Standards

Unless otherwise stated, all technical standards cited in this manual relate to the latest version of the standard that is applicable at the date of the publication of this manual.

This information is in compliance with the Performance Standards for Laser Products,' *United States Code of Federal Regulations*, 21 CFR 1040.10. In many cases, the international standards (ISO and IEC standards) have been adopted wholly or in part by national or regional standards authorities and are known locally under the designation assigned by this authority. For instance, the IEC 60825-1 has been adopted by the European Committee for Standardization as the standard EN 60825-1 and, in turn, by various national standards authorities as standards such as DIN EN 60825-1 (Germany) and BS EN 60825-1 (United Kingdom). The exact content, number and revision date of the national standard may, however, vary from that of the corresponding international standard. For further information, please contact the publisher of the respective national standard.

1.5 Laser Terminology

ISO 11145 ("Optics and Optical Instruments - Lasers and Laser Related Equipment - Vocabulary and Symbols") contains a list of laser terminology.

To prevent misunderstandings, the Chameleon Discovery NX documentation strictly differentiates between "laser" and "laser system". Thus "start laser system" means that the power is off and shall be turned on. To "start the laser" means to switch on the laser beam and start laser operation.

- A Laser
Consists of an amplifying medium capable of emitting coherent radiation with wavelengths up to 1 mm by means of stimulated emission.
- B Laser system
A laser (A), where the radiation is generated, together with essential additional facilities (E) that are necessary to operate the laser (e.g. cooling, power, and gas supply).

In addition to the terminology used by ISO 11145, IEC 60825-1 uses the term “laser product”. This term relates to any product or assembly of components which constitutes or is intended to incorporate a laser. In other words, the term “laser product” can be used in conjunction with any of the definitions contained in ISO 11145.

1.6 Units of Measurements

In this manual, units of measurement are used according to the metric system (international system of units (SI)), e.g. meter, millimeter, square meter, cubic meter, liter, kilogram, bar, pascal; and imperial system, e.g. tons, pounds, and ounces; gallons and quarts; miles, yards, feet, and inch.

Temperatures are primarily indicated in degrees celsius (°C) and fahrenheit (°F).

1.7 Feedback Regarding Documentation

If there are any comments regarding the documentation provided, please contact the Coherent Documentation Department.

In any correspondence, please provide the following:

- the document part number, revision, and date of issue,
- the section number, page number and, where applicable, the procedure step number,
- a description of any errors,
- a proposal for improvements.

1.7.1 Feedback Address

E-mail documentation.support@coherent.com

Post Coherent Inc
Documentation and Training Development Department
5100 Patrick Henry Drive
Santa Clara, CA. 95054
USA

This Page Intentionally Left Blank

2 Laser Safety Table

This laser safety information must be reviewed thoroughly prior to operating the Chameleon Discovery NX system. Safety instructions presented throughout this manual must be followed carefully. See “Laser Safety” (p. 95) for additional laser safety information and guidelines.

Table 2-1. Laser Safety Reference Table

Item	Description
Scope	This user information is in compliance with the following standards for Light-Emitting Products IEC 60825-1 “Safety of laser products - Part 1: Equipment classification and requirements” and CDRH 21 CFR Title 21 Chapter 1, Subchapter J, Part 1040 “Performance standards for light-emitting products” except for conformance with IEC 60825-1 Ed. 3 and IEC 60601-2-22 Ed. 3.1, as described in Laser Notice No. 56, dated May 8, 2019.
Hazards	
<i>Biological/Optical</i>	Exposure to laser radiation may damage the eyes or skin. Wear appropriate laser safety eyewear for protection against the specific wavelengths and laser energy being generated. See “Optical Safety” (p. 96) for additional information/guidelines.
<i>Electrical</i>	Laser uses AC and DC voltages that are potentially hazardous. The rules for electrical safety must be strictly followed. See “Electrical Safety” (p. 98) for additional information/guidelines.
<i>Chemical</i>	Contact of the laser beam with volatile or flammable substances, or released as a result of laser material processing.
Laser Classification	The Discovery NX and NX TPC are is classified as Class 4 based on 21 CFR, Subchapter J, Part 1040, section 1040.10 (c) and IEC/EN 60825-1. In this manual, the classification will be referred to as Class 4.
Control Measures	Laser incorporates protective housing, safety interlocks, remote interlock connector, key switch, laser emission indicators, beam attenuator, operator’s controls, display, and manual reset mechanism in accordance with CFR 1040.10 (f)(6)/IEC 60825-1. See “Safety Features and Compliance with Government Requirements” (p. 99) for additional information.
Warning Labels	Refer to Figure I.5.6 (p. 104) for the location of all safety labels.



WARNING!

Use of controls or adjustments or performance of procedures other than those specified herein may result in hazardous radiation exposure.

This Page Intentionally Left Blank

3 Description and Specifications

3.1 System Description

The Chameleon™ Discovery NX Laser Systems are widely tunable, high power, dual output femtosecond lasers with automated dispersion compensation.

The Discovery NX(Figure 3-1) consists of a laser head, power supply (connected by an umbilical to the laser head), a miniature recirculating unit (MRU), and a closed loop chiller.



Laser Head^a
(MRU, Power Supply, and Chiller Not Shown)

Figure 3-1. Chameleon Discovery NX Laser System

a. The non-TPC laser head is shown. The appearance of the laser head cover may vary.

3.2 Chameleon Discovery NX Laser Head

The front of the laser head has two output apertures (fixed and tunable). Operating parameters, fault handling and various system controls are remotely accessible through the RS-232 serial port, USB ports or BNC connectors. The connections are found at the rear of the laser head. Additionally there is a sync output as well as MRU and Chiller input/output connectors.

See “Controls and Indicators” (p. 29) for location and description details on the ports and connectors.

3.3 Power Supply

As well as providing power to the laser head, the power supply also includes safety features: key-switch, shutter control buttons, and an external interlock connection. There is also a fault indication LED as well as a laser emission LED. The RS-232, USB, and Sync out are all located on the laser head.

3.4 Miniature Recirculating Unit (MRU)

The MRU is a separate unit that is connected directly to the laser head using two PTFE hoses. It performs the task of cleaning, conditioning, and dehumidifying the air inside the laser head to maintain stability and long-term operation. See “MRU X1” (p. 73) for specific information about the MRU.

3.5 Closed Loop Chiller

The chiller removes heat from the amplifier cavity and maintains thermal equilibrium for the entire system. The water flow is a closed loop between the laser head and rack-mountable chiller unit. Refer to “Chiller Water Coolant” (p. 25) for more information.

3.6 Specifications

The Customer Datasheet shipped with each Chameleon Discovery provides a detailed description of system performance. The general specifications and requirements for the Coherent Chameleon Discovery NX can be found at:

<https://www.coherent.com/lasers/laser/chameleon-discovery-nx>.

3.7 Environmental Requirements

The storage and operating environmental requirements are stated in Table 3-1.

Table 3-1. Environmental Requirements

Description	Parameter
Operation Temperature Range (°C)	15 to 35 (59 to 95°F)
Storage Temperature Range (°C)	0 to 40 (32 to 104°F)
Humidity	Non-condensing
Altitude (m)	< 2000

3.8 System Dimensions & Weight

The information below provides the dimensions for the different versions of the laser head, the power supply, MRU, and chiller. See Table 3-2 for a summary of dimensions and weight.

Table 3-2. System Dimensions and Weight

	Length	Width	Height	Weight
Head^a	820.8 mm (32.31 in.)	445.2 mm (17.53 in.)	286.7 mm (11.29 in.)	83 kg (182.98 lb.)
TPC Head^a	1010.8 mm (39.80 in.)	445.2 mm (17.53 in.)	286.7 mm (11.29 in.)	98 kg (216.05 lb.)
Power Supply	412.9 mm (16.45 in.)	483.0 mm (19.02 in.)	132.3 mm (5.21 in.)	11 kg (24.25 lb.)

Table 3-2. System Dimensions and Weight (Continued)

	Length	Width	Height	Weight
MRU X1	450.09 mm (17.75 in.)	431.8 mm (17.00 in.)	95.4 mm (3.76 in.)	12 kg (26.5 lb.)
Chiller^b	400 mm (15.75 in.)	484 mm (19.06 in.)	267 mm (10.51 in.)	21 kg (46.29 lb.)

a. The Chameleon Discovery NX is available in different versions. Verify the version for the correct head dimensions.
 b. Dimension values are of the recommended chiller SMC HECR Series.

3.8.1 Laser Head Dimensions

The laser head dimensions shown in below are for a Discovery NX (TPC) head. Verify the system type to determine correct dimensions for your system.

3.8.1.1 Discovery NX Laser Head¹

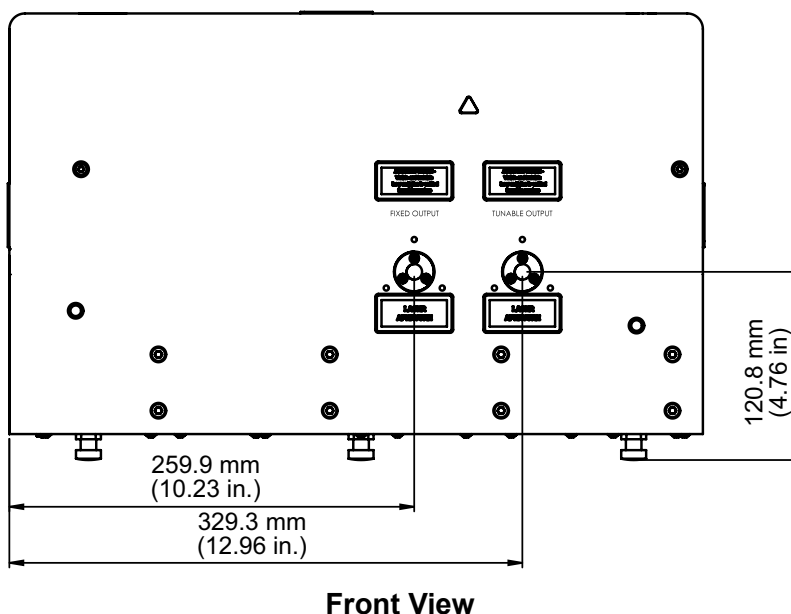
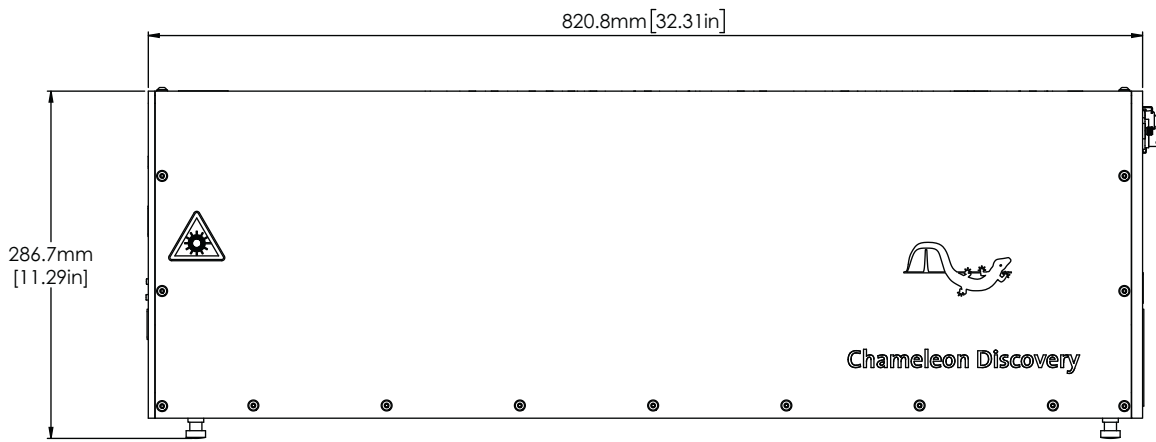

Figure 3-2. Discovery NX Head Dimensions

1. The Chameleon Discovery is available in different versions. Verify the version for the correct head dimensions. The appearance of the laser head cover may vary.



Top View



Side View

Figure 3-2. Discovery NX Head Dimensions (Continued)

3.8.1.2 Discovery NX TPC Laser Head¹

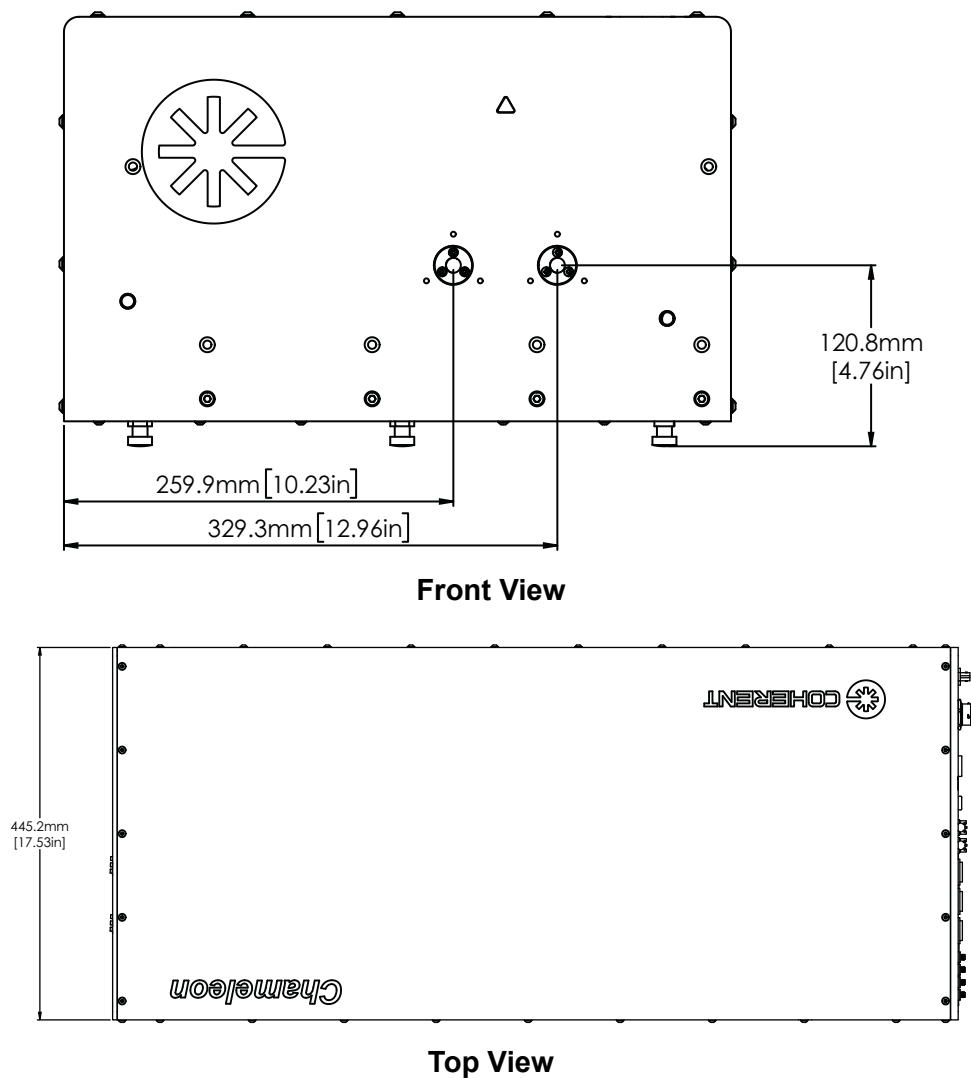
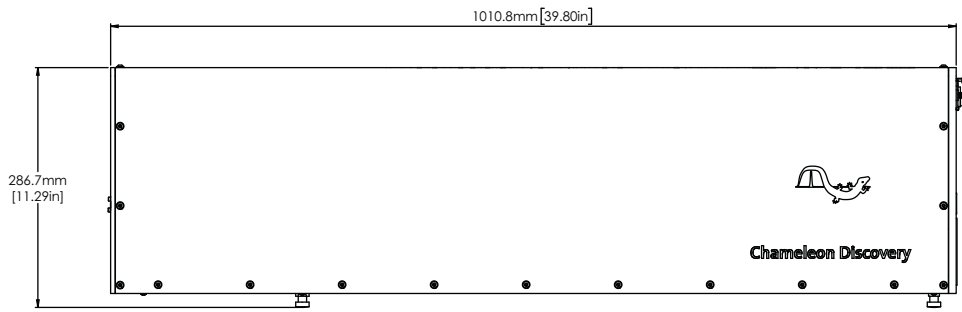

Figure 3-3. NX TPC Laser Head Dimensions

1. The Chameleon Discovery NX Laser System is available in different versions. Verify the version for the correct head dimensions. The appearance of the laser head cover may vary.



Side View

Figure 3-3. NX TPC Laser Head Dimensions (Continued)

3.8.2

Chameleon Discovery NX Power Supply

The power supply dimensions shown in below are for both a Discovery NX and Discovery NX TPC system.

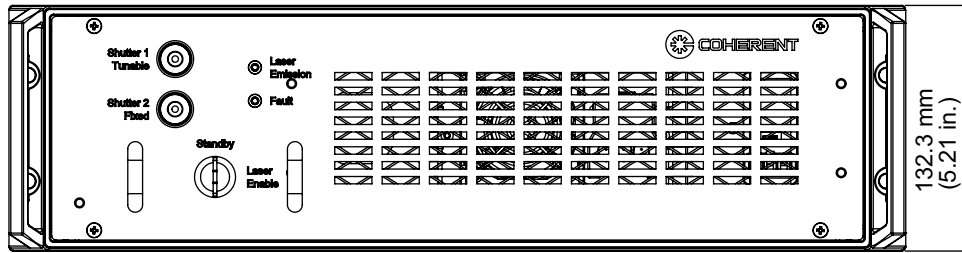

Front View

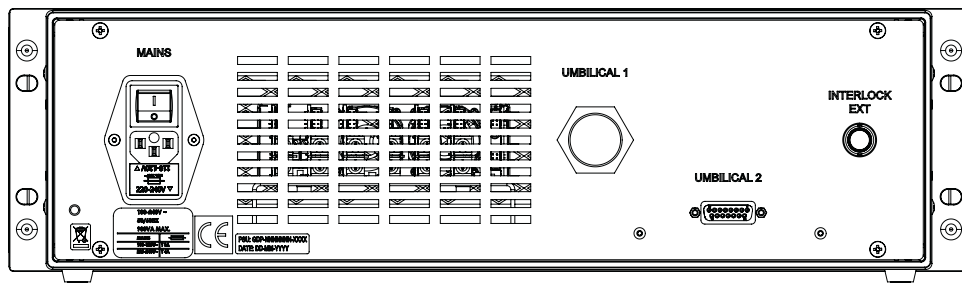

Rear View

Figure 3-4. Power Supply Dimensions

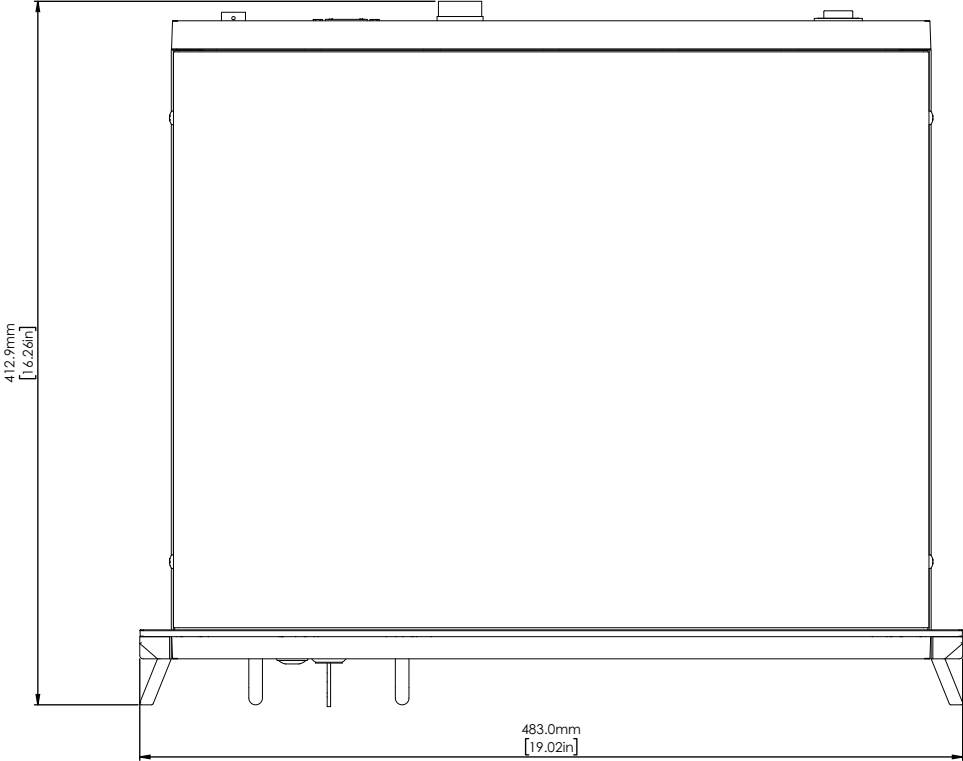

Top View

Figure 3-4. Power Supply Dimensions (Continued)

3.8.3

Chiller

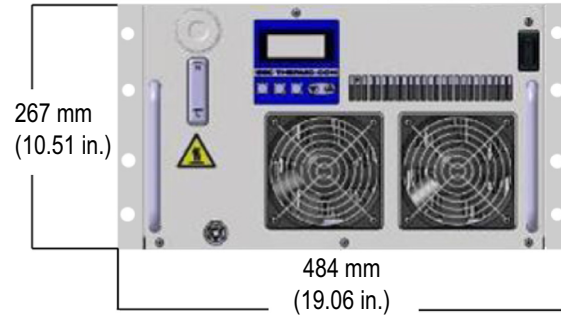

Front View

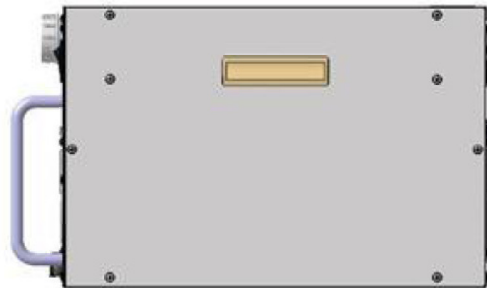

Side View

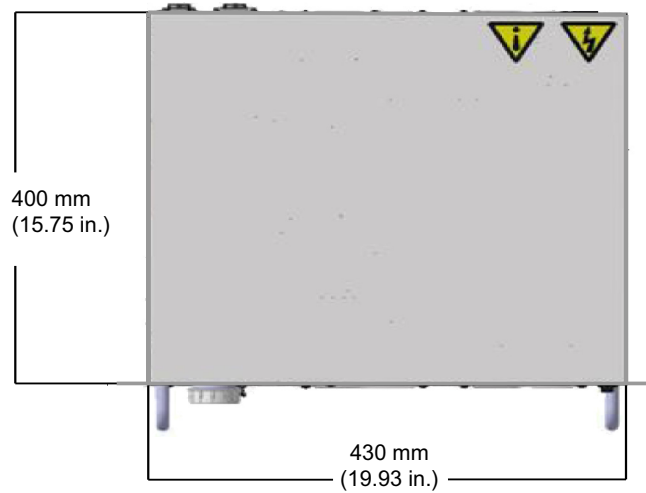

Top View

Figure 3-5. SMC Rack Mount Chiller

3.8.4

MRU X1

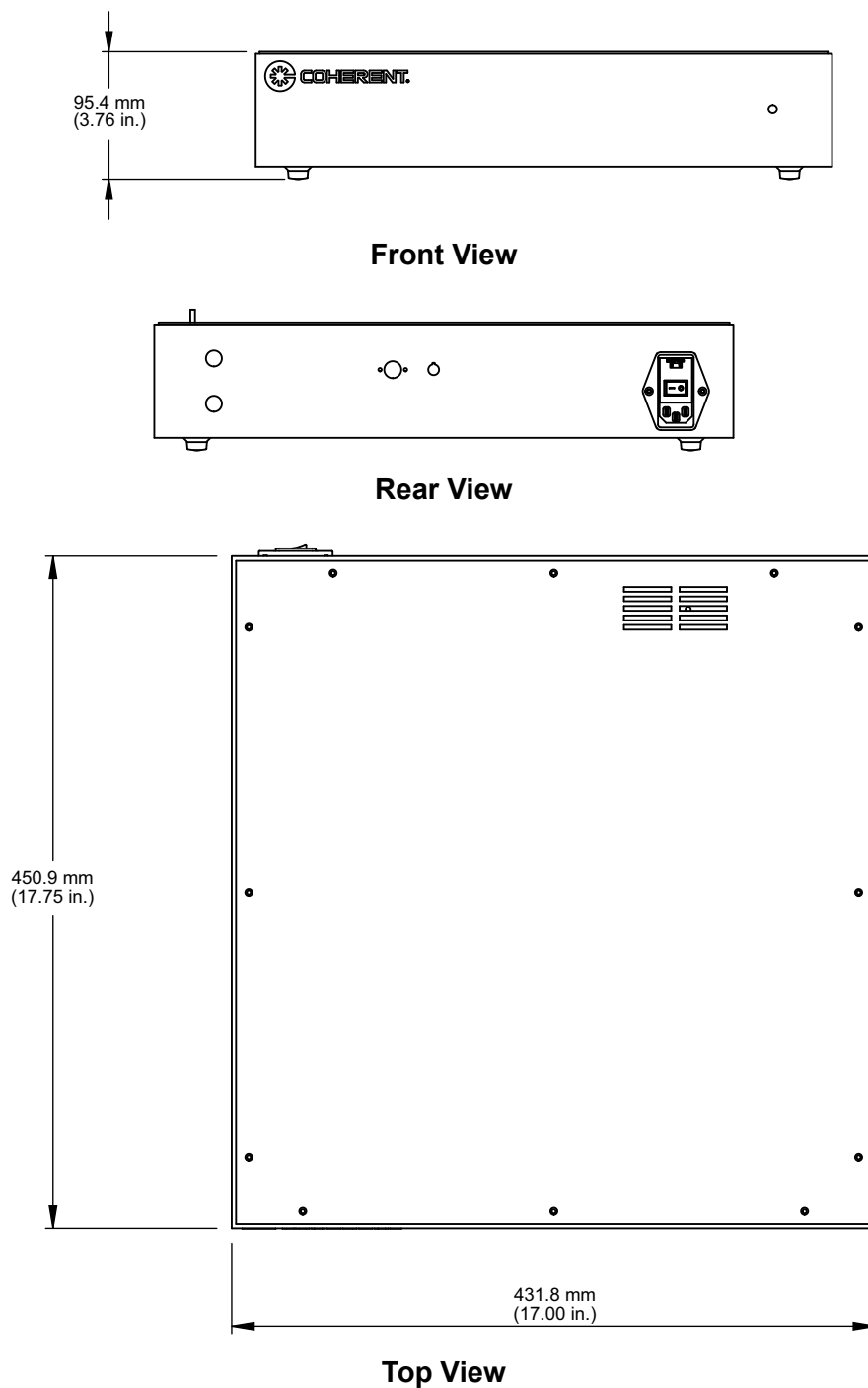

Figure 3-6. MRU X1

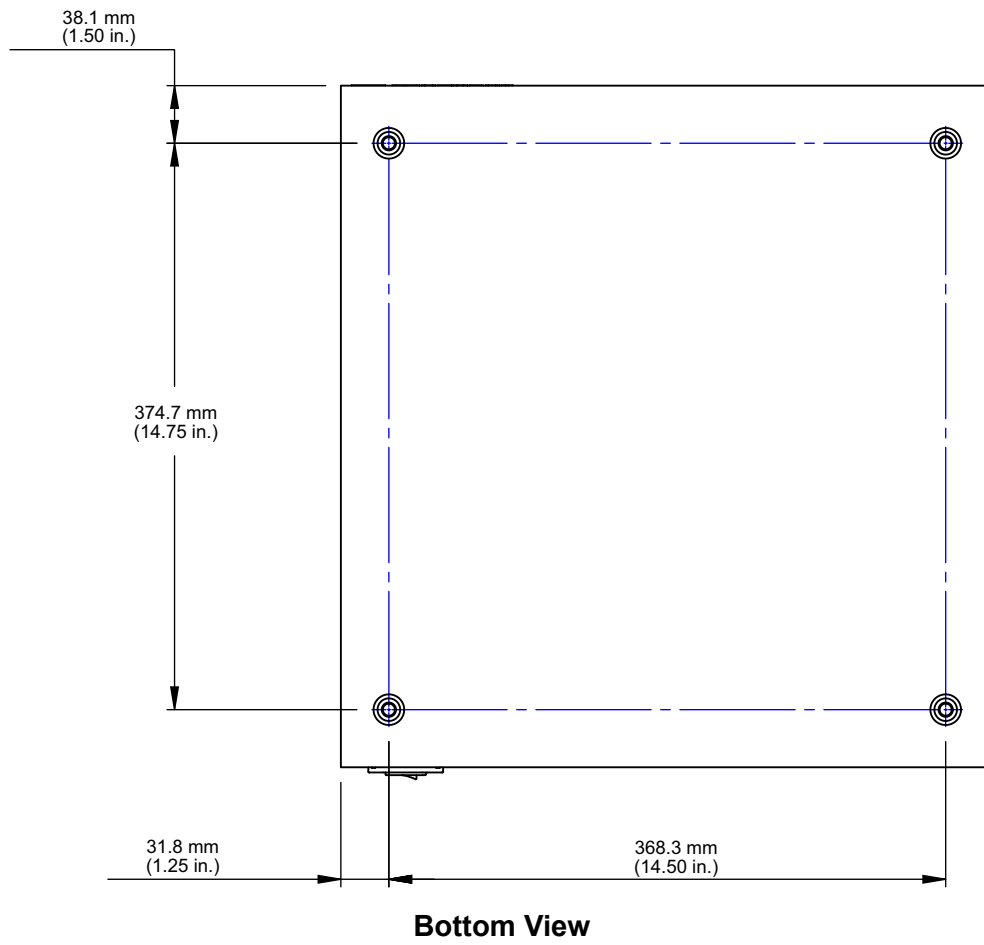

Figure 3-6. MRU X1 (Continued)

This Page Intentionally Left Blank

4 Installation



NOTICE

This section describes the installation of Discovery Laser Systems. Installation information for the Discovery TPC is detailed in “TPC Modulator Control” (p. 51).

4.1 Receiving and Inspection

Inspect shipping containers for signs of rough handling or damage, and immediately report any damage to the shipping carrier and to Coherent or an authorized representative.



NOTICE

The Chameleon Discovery NX must be installed by authorized Coherent personnel. Do not remove the system from its shipping containers.



CAUTION!

The Discovery laser head weighs up to 98 kg, therefore safe lifting precautions should be adhered to while transporting the laser head.



CAUTION!

When unpacking keep fingers away from the bottom of the laser head while placing onto a table or platform.

4.1.1 Lifting Handles (Removable)

Removable handles are provided to assist in moving the laser head.

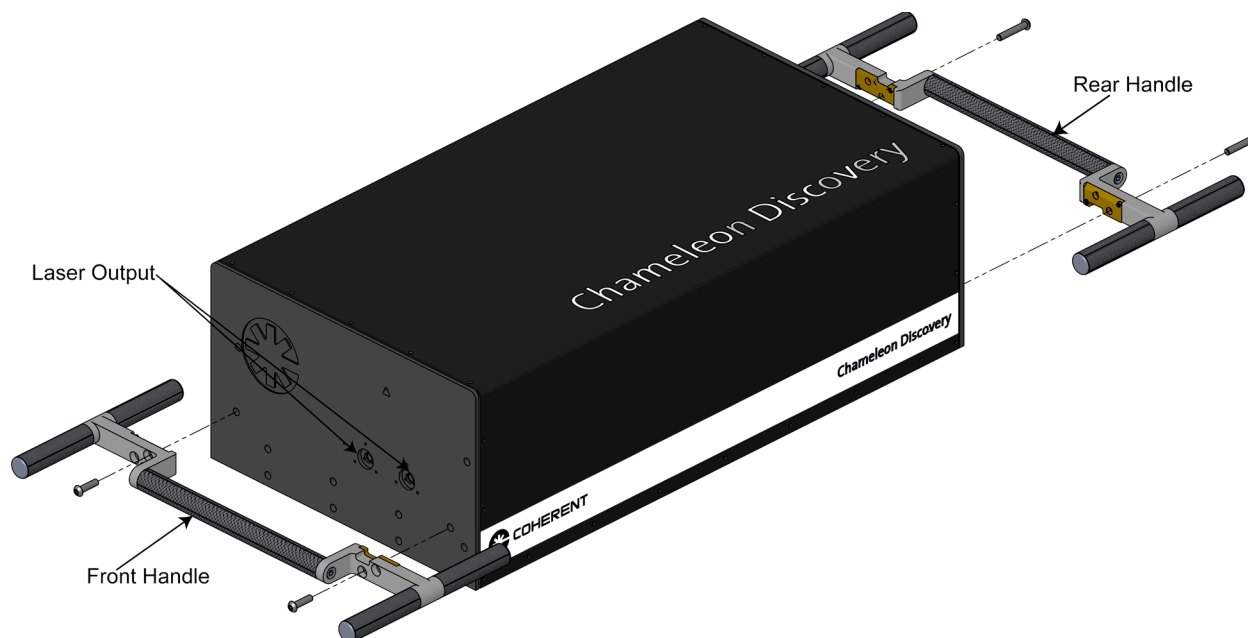

Figure 4-1. Lifting Handles (Removable)



NOTICE

Verify all four bolts are securely tightened in the lifting handles prior to moving or lifting the laser head.

Lifting of the laser must be carried out with regard to safe handling and lifting procedures, and in accordance with local laws. Handles are supplied and can be attached to aid in the lifting process. These handles can be used by up to 6 persons.

4.2 Fuse Verification

The power supply requires different fuses for 100 V and 240 V operation, as listed in Table 4-1.

**NOTICE**

Confirm that the correct fuses are installed before turning the system ON. Refer to Table 4-1. If necessary, physically change the fuses in the power supply. Spare fuses are provided in the accessory kit.

Table 4-1. Fuse Ratings

Operating Voltage	Power Supply Fuse Rating
100 - 120 V	8 A
220 -240 V	4 A

4.3 Chiller Water Coolant

Fill the chiller reservoir with the provided coolant, CoolFlow PN 1234080.

**NOTICE**

The use of CoolFlow IGE premixed coolant is critical to the long-term performance of the system. Use of any other coolant will void the warranty. CoolFlow IGE coolant can be purchased from Coherent.

Wear gloves when filling the chiller to prevent the introduction of organic material to the water lines.

For optimum operation, replace the coolant every six (6) months.

4.4 System Connections

Figure 4-2 on page 4-26 provides a diagram of all system connections. The required cables and hoses are included in the Chameleon Discovery NX accessory kit.

The modulator installation instructions for the Discovery NX TPC Laser Systems are treated separately and start in “TPC Modulator Control” (p. 51).

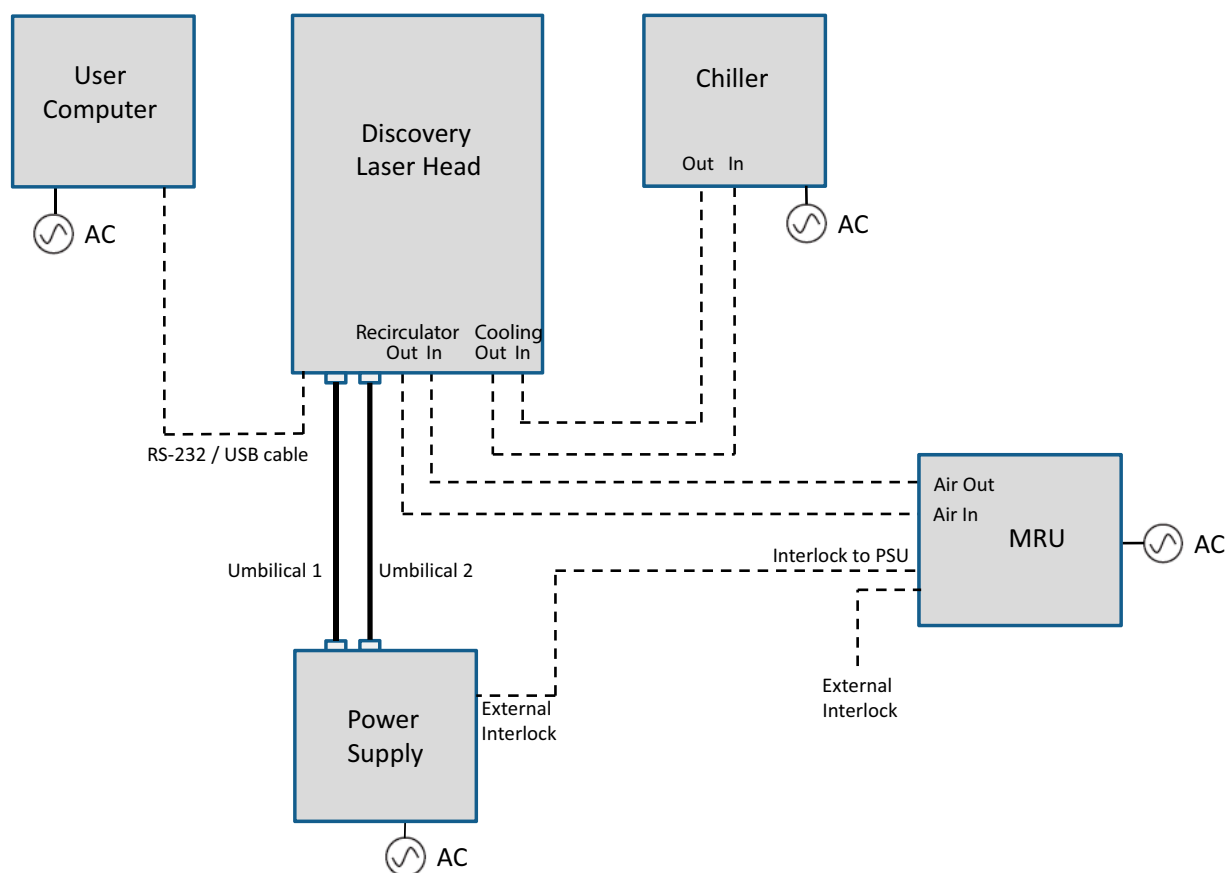

Figure 4-2. Chameleon Discovery NX NX Laser System Connections



NOTICE

The mains switch for the power supply must be accessible at all times. This can be either the mains switch on the power supply or the mains switch on the wall.

- The power supply, chiller, MRU X1, and computer require individual connections to facility power.



NOTICE

Do not replace the detachable mains cable with one that is not rated for this laser system.

- Install the power supply so that air flow to the front and back sides is not obstructed. If installing the power supply in a 19 in. (48 cm) equipment rack, allow a minimum horizontal clearance of 18 in. (46 cm) for the front panel of the power supply.
- This product is intended for indoor use, with pollution degree 2.
- It must be installed in a location with an over-voltage category 2 or better, limiting transients seen by the mains input to a maximum of 2500 V. The mains input voltage range is 100 - 240 Vac \pm 10%.
- The direction of water flow is important. Connect the chiller OUT to the laser head COOLING IN. Connect the laser head COOLING OUT to the chiller RETURN using the provided short hose.
- The Power Supply connects to the Discovery laser head via two umbilical cables.
- The computer connects to the laser head using a USB or RS-232 cable. It is recommended to use either USB or RS-232 but not RS-232 via USB to RS-232 converter.



If the system installation is in an area with unstable AC mains supply, Coherent recommends the use of a suitable surge protector for the Discovery NX system.

4.5

External Interlock

An interlock connector is located on the power supply rear panel, and the system will not operate with this circuit open.

Since the laser system should never be operated without purified air from the MRU, the MRU X1 is positioned in the middle of the interlock loop effectively moving the interlock connector to the MRU X1 rear panel. This external interlock must be closed (by jumper or switch contacts) and the MRU pump must operate before the interlock loop circuit is satisfied.

The laser system includes the interlock cable that connects the power supply to the MRU X1 and an interlock over-ride (defeat) jumper (a shorted plug) that can be used in a customer-designed interlock circuit.

Local safety regulations and customer application will dictate which interlock method to employ. A basic interlock circuit using a control or door switch is provided in “MRU X1” (p. 73). A more advanced interlock circuit,

complete with a "Laser In Use" warning light is shown below in Figure 4-3. Note that the interlock circuit provides insufficient power to drive a load, therefore do not place any load on the external interlock circuit.



NOTICE

The interlock connection on the power supply rear panel must be connected to the MRU X1 using the cable provided. The user-furnished external interlock is then connected to the HR10 connector on the MRU X1 (see "MRU X1" (p. 73)). This interlock method prevents the laser from operating if the MRU is not running or the external interlock circuit is opened.

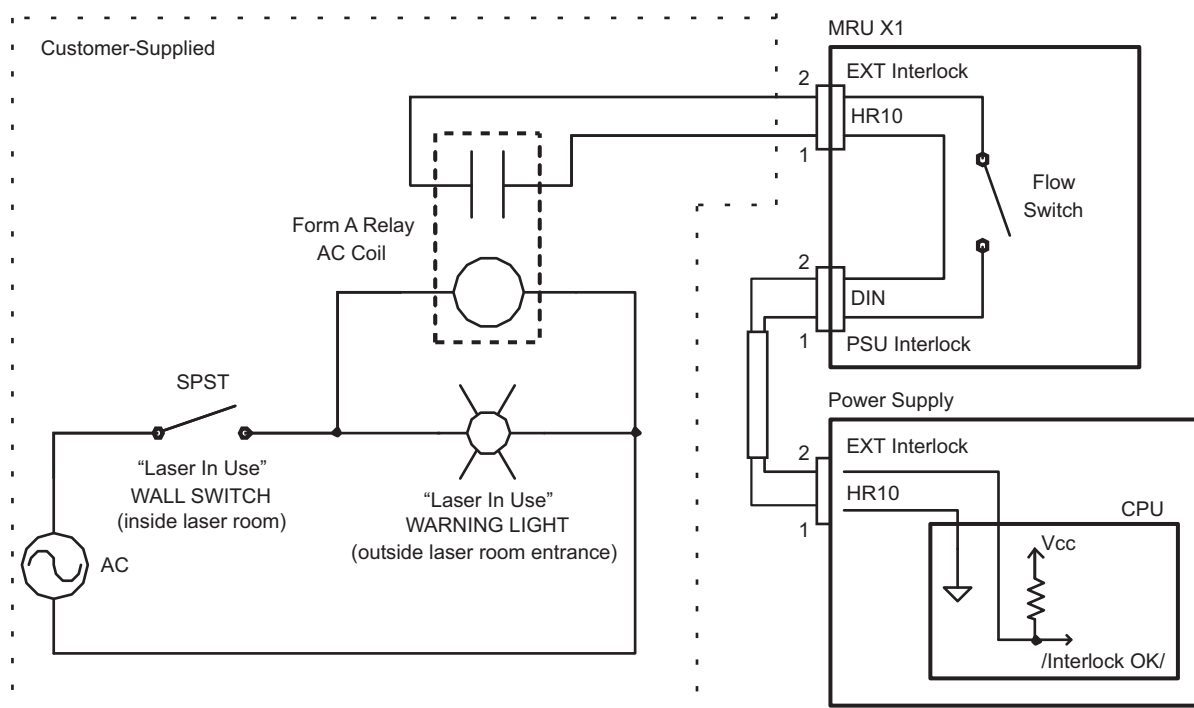

Figure 4-3. Example External Interlock Circuit



NOTICE

Any external interlock circuit should be equivalent to a mechanical closure of the circuit. Under no circumstances should an external voltage or current source be connected to this circuit. External interlock circuitry must be isolated from all other electrical circuits or grounds.

5 Controls, Indicators, and Features

5.1 Controls and Indicators

Figure 5-1 (p. 29) and Table 5-1 (p. 31) describe the controls, indicators, and features of the Chameleon Discovery NX NX laser head models.

Figure 5-2 (p. 32) and Table 5-2 (p. 33) describe the controls, indicators, and features of the Chameleon Discovery NX NX power supply model.

5.1.1 Laser Head

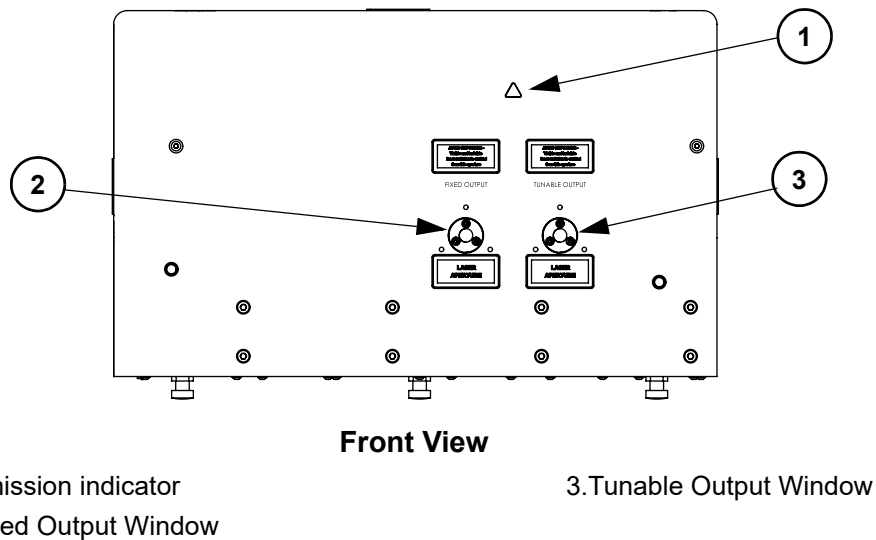
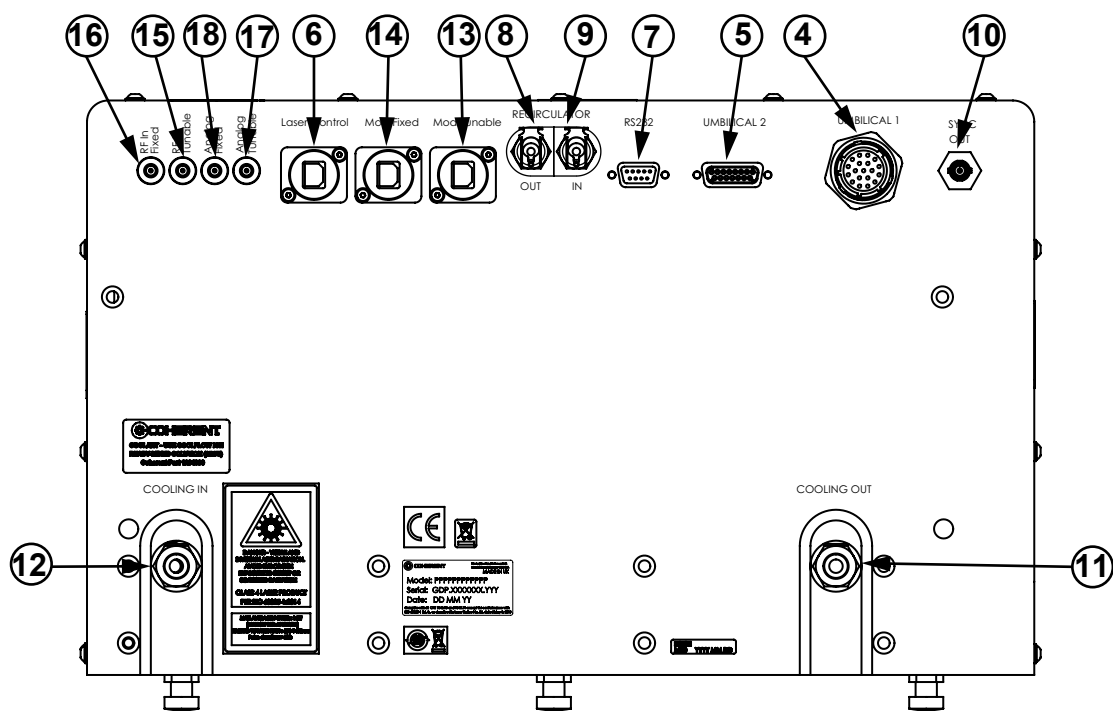

Figure 5-1. Laser Head - Features, Controls, and Indicators



Rear View

- | | |
|---------------------|-----------------------------------|
| 4. Umbilical 1 | 12. Cooling In |
| 5. Umbilical 2 | 13. Mod - Tunable Modulator (USB) |
| 6. USB | 14. Mod - Fixed Modulator (USB) |
| 7. RS-232 | 15. RF In Tunable |
| 8. Recirculator Out | 16. RF In Fixed |
| 9. Recirculator In | 17. Analog Tunable |
| 10. Sync Out | 18. Analog Fixed |
| 11. Cooling Out | |

Figure 5-1. Laser Head - Features, Controls, and Indicators (Continued)

5.1.1.1 Laser Head Feature, Controls and Indicators Description ¹

Table 5-1. Discovery NX (TPC) Laser Head - Features, Controls, and Indicators

Item	Control	Function
1	Emission indicator	Illuminated when capable of emitting laser light.
2	Fixed Output Window	Laser light is emitted from this aperture when the laser is on and the shutter is open.
3	Tunable Output Window	Laser light is emitted from this aperture when the laser is on and the shutter is open.
4	Umbilical 1	Carries electrical power and various signals between the power supply and head.
5	Umbilical 2	Carries electrical power and various signals between the power supply and head.
6	USB Connector	Allows external computer control of the laser system.
7	RS-232	Allows external computer control of the laser system.
8	Recirculator Out	Connects the MRU to the laser head. The recirculator should be left on at all times.
9	Recirculator In	Connects the MRU to the laser head. The recirculator should be left on at all times.
10	Sync Out	Synchronizes external equipment with the Chameleon Discovery output pulse. This output can also be used to monitor the output pulse with an oscilloscope.
11	Cooling Out	Outlet connector for coolant to the chiller.
12	Cooling In	Inlet connector for coolant from the chiller.
13	Mod- Tunable ¹	Serial connection to the Tunable AOM driver.
14	Mod-Fixed ¹	Serial connection to the Fixed (1040 nm) AOM driver.
15	RF In Tunable ¹	RF input sent directly to the Tunable AOM.
16	RF in Fixed ¹	RF input sent directly to the Fixed (1040 nm) AOM.
17	Analog Tunable ¹	0-10 Vdc input to set/modulate Tunable laser power.
18	Analog Fixed ¹	0-10 Vdc input to set/modulate Fixed laser power.

5.1.2 Power Supply

1. Options # 13 to 18 are only functional on the TPC Head

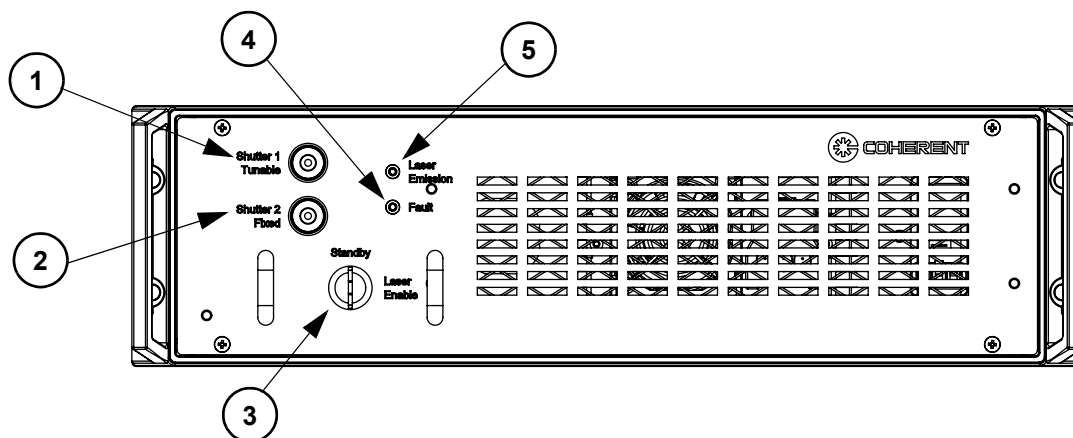

Front View

- 1.Shutter 1 Tunable
- 2.Shutter 2 Fixed
- 3.Keyswitch

- 4.Fault LED
- 5.Laser Emission LED

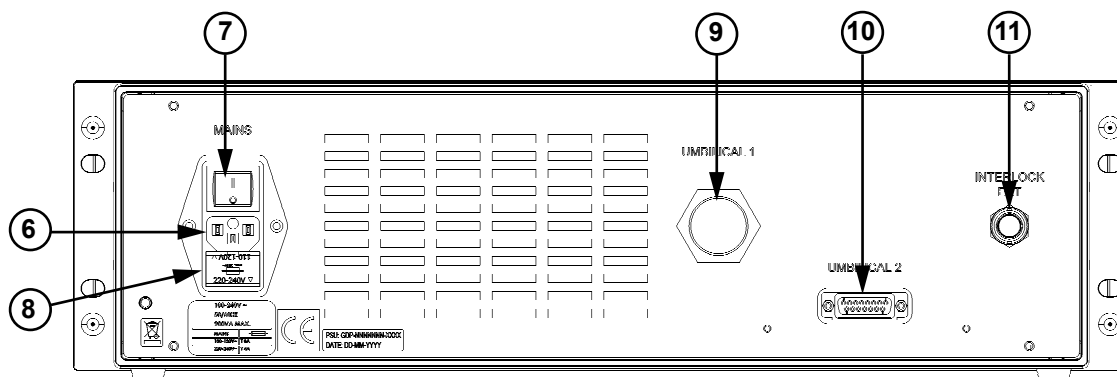

Rear View

- 6.AC Mains Input
- 7.Power ON/OFF Switch
- 8.Fuse Location

- 9. Umbilical 1
- 10.Umbilical 2
- 11.Interlock Connector

Figure 5-2. Power Supply - Features, Controls and Indicators

5.1.2.1 Power Supply Feature, Controls and Indicators Description

Table 5-2. Discovery NX (TPC) Power Supply Controls, Indicators and Features

Item	Control	Function
1	Shutter 1 Tunable Indicator	This LED indicates that the shutter is open for the Tunable exit aperture when it is lit. The push button can manually open and close the shutter. The LED is turned off when the shutter is closed.
2	Shutter 2 Fixed Indicator	This LED indicates that the shutter is open for the Fixed exit aperture when it is lit. The push button can manually open and close the shutter. The LED is turned off when the shutter is closed.
3	Keyswitch	Places the laser in either the Standby or Enable state. The key can be removed when in the Standby position to prevent unauthorized operation. It cannot be removed when in the Laser Enable position.
4	Fault Indicator	This indicator will flash for the first few minutes after power up to indicate the system is warming up. A fault condition exists when this indicator is constantly on.
5	Laser Emission Indicator	Lights when laser emission is possible (when power supply AC is on).
6	AC Mains Power Cord	Connects the power supply to AC facility power.
7	Power ON/OFF Switch	Applies/removes all AC electrical power from the laser.
8	Fuse Location	Location of fuses. See "Fuse Verification" (p. 24) for more details.
9	Umbilical 1	Carries electrical power and various signals between the power supply and the laser head.
10	Umbilical 2	Carries electrical power and various signals between the power supply and the laser head.
11	Interlock Connector	Allows connection of an external interlock. The laser will not operate when this connector is open.

This Page Intentionally Left Blank

6 Operation



WARNING!

All personnel in the area must wear laser safety glasses to protect against laser radiation. Read "Laser Safety" and be familiar with proper laser safety practices.

Laser safety eye wear must be rated to protect against the wavelengths produced by the Discovery. Refer to Label 8. Maximum Radiation Label, pg. 109 in Figure I-1.

The Discovery is usually operated with the laser head and power supply covers in place. Removal of the laser head cover allows access to hazardous visible and invisible radiation. Covers must only be removed by trained personnel for service and maintenance.



WARNING!

Do not open the power supply or laser head covers in the Chameleon Discovery laser system. There are hazardous voltages and currents. There is no cover interlock to eliminate these dangers upon removal of the cover. Opening these compartments voids the warranty.



NOTICE

Do not replace the detachable mains cable with a cable not rated for this laser system.



NOTICE

The power supply requires different fuses for 100 V and 240 V operation. Refer to Table 4-1 (p. 25) and confirm the correct fuses are installed before operation.

6.1 Operating States

Table 6-1 summarizes the three operating states of the Chameleon Discovery laser system.

Table 6-1. Chameleon Discovery NX Operating States

State	Switch Positions	Status
OFF	<ul style="list-style-type: none"> Main Power Switches for Power supply: OFF Main Power Switch for MRU and Chiller: OFF 	<ul style="list-style-type: none"> All functions off No laser output
STANDBY	<ul style="list-style-type: none"> Main Power Switches for Power supply and chiller: ON Main Power Switch for MRU: ON Keyswitch: STANDBY 	<ul style="list-style-type: none"> Pump laser: off System ready for activation No laser output
ENABLED	<ul style="list-style-type: none"> Main Power Switches: ON Keyswitch: LASER ENABLE 	<ul style="list-style-type: none"> Pump laser: on System ready to open shutters

6.1.1 Turn-on (Cold Start)

Use the cold start procedure when the primary power is removed from the system components, *i.e.*, the system is in the OFF condition as indicated Table 6-1.

1. Verify the key switch on the power supply front panel is in the STANDBY position.
2. Turn ON the MRU.
3. Turn ON the chiller and check for water leaks. Verify the chiller temperature is set to 20°C.
4. Turn ON the power supply.

The AC ON and LASER EMISSION indicators will light.



CAUTION!

Ensure that all personnel in the area wear laser safety glasses. Make certain that the laser output is directed at an intended target, beam block or power meter, and that the correct output port has been selected. For your safety, **ONLY** the desired output port should be opened at any given time.

5. Open the Chameleon Discovery GUI.

- Wait until the fault LED stops flashing.
6. Turn the key switch to LASER ENABLE. Allow one hour for the system to thermally stabilize.
 7. To open a shutter press the required SHUTTER pushbutton on the GUI or front panel of the power supply, or send the relevant RS-232 serial shutter command (see Table 7-4 (p. 45)). The opening of the shutter is accompanied by a click, and the LED will light when the shutter is open.
 8. **TPC Systems Only:** Choose an modulator communication configuration first, followed by a power control configuration. The communication and control of the TPC model are described fully in “TPC Modulator Control” (p. 51), including a full definition of terms.
 - a.) Choose either:
 - Integrated
 - Direct USB

communication with the modulator system and make serial connections as appropriate.
 - b.) Choose power control method:
 - Software power control
 - Analog power control



There is also a Direct RF configuration, which precludes the configurations cited above. See “TPC Modulator Control” (p. 51) for full details.

6.1.2

Daily Turn-on (Warm Start)

A warm start may be performed when the system is in the STANDBY state as described in Table 6-1 (p. 36). The recommended daily operation of the Chameleon Discovery NX is to use this warm start procedure in conjunction with the daily turn-off procedure described below. The power supply, MRU, and chiller are left on continuously to reduce the time required to reach full thermal stability.

1. Verify the chiller temperature (20°C default value).
2. Verify the MRU is switched to ON.
3. Turn the key switch to LASER ENABLE on the front panel of the power supply. **Allow ONE HOUR** for the system to stabilize.



CAUTION!

Ensure that all personnel in the area wear laser safety glasses. Make certain that the laser output is directed at an intended target, beam block or power meter, and that the correct output port has been selected. For your safety, **ONLY** the desired output port should be opened at any given time to prevent unnecessary exposure to hazardous radiation.

4. To open a shutter press the required SHUTTER pushbutton on the GUI or front panel of the power supply, or send the relevant RS-232 shutter command (see Table 7-4 (p. 45)). The opening of the shutter is accompanied by a click, and the LED will light when the shutter is open. Monitor the output power and adjust the settings via the GUI.

6.2 System Turn-off

6.2.1 Turn-off (Daily Use)

When the Discovery is being used on a daily basis, turn-off consists of the following:

1. Close the SHUTTER pushbutton in the GUI, on the front panel of the PSU, or send the relevant RS-232 command (see Table 7-4 (p. 45)).
2. Turn the key switch to STANDBY. The system is now in the STANDBY state described in Table 6-1 (p. 36). The power supply, MRU, and chiller are left on to decrease the time required for the Discovery to fully stabilize following the next turn-on.

6.2.2 Turn-off (Complete Shutdown)

This procedure removes all power from the Discovery. It is recommended if no operation is anticipated for a long period of time (*i.e.*, more than two days) or as required for system maintenance.

1. Close the shutter if necessary by pressing the SHUTTER pushbutton in the GUI or front panel of the power supply or sending the relevant RS-232 command (see Table 7-4 (p. 45)).
2. Turn the power supply key switch to STANDBY.
3. Turn OFF mains power at the power supply and then the chiller.



NOTICE

If the system is to be turned off for more than one month, Coherent recommends draining the chiller and fluid lines to prevent degradation of the cooling channels.

The key may be removed to prevent system turn-on.

This Page Intentionally Left Blank

7 External Computer Control

7.1 Chameleon Discovery NX Interface

This section provides the details to interface a Chameleon Discovery laser with a remote computer. This task is done through the RS-232 or USB laser control port on the rear of the laser head.

The RS-232 or USB interface is based on a set of laser control instructions. These instructions consist of commands that affect laser operation and queries that tell the laser to return status information to the host. The instruction set is sufficient to support user-written programs that control the functions of the Chameleon Discovery. For convenience, control can also be achieved via the Chameleon Discovery GUI. Details for the GUI can be found in the Chameleon Discovery GUI User's Guide.

7.1.1 Communication Syntax

Communication with the Chameleon Discovery is with two types of instructions:

- Commands that set the values of laser operating parameters.
- Queries which request the laser to return the value of an operating parameter.

Any instruction to the laser consists of a command or query written as a string of ASCII characters and terminated by a carriage return and linefeed (<CR><LF>).

For example:

```
LASER = 1<CR><LF>
```

Switches the Chameleon Discovery from
STANDBY to ON.

The laser always responds to an instruction by returning a message terminated by a carriage return and linefeed. Table 7-1 lists the possible responses from the laser.

Table 7-1. Response from Laser after Receiving Instruction

Instruction Sent To Laser	Response From Laser			
	Echo Off Prompt Off	Echo Off Prompt On	Echo On Prompt Off	Echo On Prompt On
Command + <CR><LF>	<CR><LF>	Chameleon><CR> <LF>	Command + <CR><LF>	Chameleon> Command + <CR><LF>
Query + <CR><LF>	Data + <CR><LF>	Chameleon> Data + <CR><LF>	Query + Data + <CR><LF>	Chameleon> Query + Data + <CR><LF>
Command + <CR><LF> (Illegal operand)	RANGE ERROR: + Command + <CR><LF>	Chameleon> RANGE ERROR: + Command + <CR><LF>	Command + RANGE ERROR: + Command + <CR><LF>	Chameleon> Command + RANGE ERROR: + Command + <CR><LF>
Command <CR><LF> (Illegal instruction)	Command Error: + Command + <CR><LF>	Chameleon> Command Error: + Command + <CR><LF>	Command + Command Error: + Command + <CR><LF>	Chameleon> Command + Command Error: + Command + <CR><LF>
Query<CR><LF> (Illegal instruction)	Query Error: + Query + <CR><LF>	Chameleon> Query Error: + Query + <CR><LF>	Query + Query Error: + Query + <CR><LF>	Chameleon> Query + Query Error: + Query + <CR><LF>

1. Multiple items are separated by the “&” character. For example, a list of system faults is returned as “3&5&6.”



For correct handshaking, communication programs must wait until the <CR><LF> is returned from the laser before the next instruction is sent.

7.1.1.1

ECHO Mode

The Chameleon Discovery provides an “echo” mode in which each character transmitted to the laser is echoed to the host. This feature can be turned on or off using the ECHO command.

7.1.1.2 PROMPT Mode

The Chameleon Discovery provides a “prompt” mode for terminal operation in which the laser returns; for example, “Chameleon>” after each command. This feature can be turned on or off using the “PROMPT” command.

7.1.2 RS-232 Interface Connection

The Chameleon Discovery laser’s RS-232 port configuration is described in Table 7-2 and typical cable requirements are shown in Figure 7-1. The 9-pin RS-232 port is configured as data communications equipment (DCE) device using only pins 2 (serial data out), 3 (serial data in) and 5 (signal ground). Handshake lines RTS, CTS, DTR and DSR (pins 4, 6, 7 and 8) are not used and have no connections inside the laser head.

7.1.2.1 RS-232 Configuration

Table 7-2. RS-232 Port Description

Parameter	Value
Data bits	8
Stop bits	1
Parity	none
Baud rate	19200

7.1.3 USB Interface Connection¹

Before connecting the external PC to the laser head, it is recommended that the user first install the Chameleon Discovery GUI. This ensures that the correct drivers are installed. Refer to the Chameleon Discovery GUI Guide for more information.

When the computer is plugged into the laser, the COM port will be automatically created. The Chameleon Discovery laser’s USB configuration is described in Table 7-3.

1. On rare occasions, the ferrite ring in the accessory kit may be required to prevent Coherent GUI drop-out. If required, fit the ferrite ring at the laser head end of the USB cable.

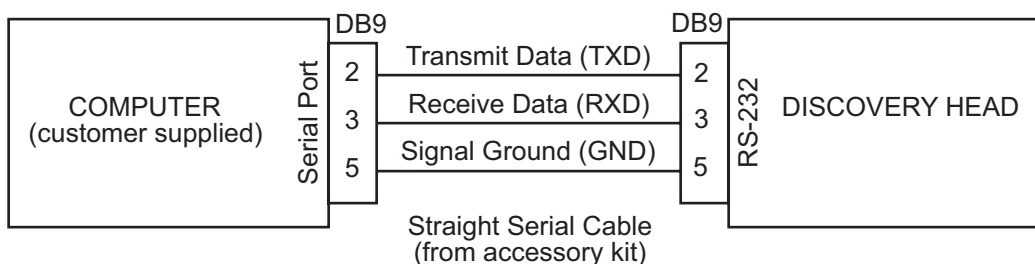

Figure 7-1. RS-232 Pin Configuration

7.1.3.1 USB Configuration

Table 7-3. USB Port Description

Parameter	Value
Data bits	Any
Stop bits	Any
Parity	Any
Baud rate	Any

7.1.4 Instruction Set

Table 7-4 (below) and Table 7-5 (p. 47) describe the instructions (long and short forms) for use in RS-232 or USB with the Chameleon Discovery NX laser system.

7.1.4.1 Command Set

Table 7-4. Chameleon Discovery NX Commands



Commands	Action Performed
General Setup	
ECHO=n E=n	Turns ECHO state on/off n = 0 Off n = 1 On
Prompt=n	Turns CHAMELEON>prompt on/off n = 0 Prompt Off n = 1 Prompt On
EOT=n	Enable / disable end of text character 1 = Enable 0 = Disable (default)
Laser Operation	
LASER=n L=n	Changes the soft key state n = 0 Off sn = 1 On  Keyswitch must be in the ON position.
FC	Clears fault if it is no longer active
ALIGNFIXED=n	Accesses alignment mode for the fixed output n = 1 Enable n = 0 Disable  Alignment mode is only required for non-TPC systems. Modulators within a TPC system can reduce the power for alignment applications.
ALIGNVAR=n ALIGN=n	Accesses alignment mode for the tunable output n = 1 Enable n = 0 Disable
SVAR=n SHUTTER=n S=n	Changes state of the tunable output external shutter n = 0 Closed n = 1 Open

Table 7-4. Chameleon Discovery NX Commands (Continued)

Commands	Action Performed
SFIXED=n	Changes state of the fixed output external shutter n = 0 Closed n = 1 Open
WAVELENGTH=nnn VW=nnn WV=nnn	Sets the wavelength to the specific value in nanometers
WAVELENGTH STEP=nnn VWS=n WVS=n	Changes the wavelength by the specified amount in nanometers
HEARTBEAT=n HB=n	When enabled, shuts the laser down if no RS-232 activity occurs within a time specified by the heartbeat rate (HBR). n = 1 Enables heartbeat n = 0 Disables heartbeat
HEARTBEATRATE=nnn HBR= nnn	Specifies to time-out period (between 1 to 100 seconds) for laser shut down in the absence of RS-232 activity.
Pre-compensator	
GDDCURVE=xx	Sets the GDD calibration curve xx = curve number Switches the system into auto GDD. Reserve curve 0 for zero dispersion curve.
GDDCURVEN=xxxxxx	Selects the GDD curve by name xxxxxx
GDD=xxxxx	Sets the GDD value manually xxxxx = GDD in fs ² Switches the system into manual GDD
SETCURVEN:x=yyyyyy	Changes the name of calibration curve x to yyyyyy Note: All curve names are automatically converted to upper case.
SETCURVEPT:ww=x: yyyy:zzzz	Changes curve ww point x to zzzzz fs ² at yyyy nm
DELCURVE=xx	Deletes curve number xx
DELCURVEPT=x	Deletes the last point in a curve

7.1.4.2

Query Set

Table 7-5. Chameleon Discovery Queries (Sheet 1 of 3)

Queries	Returned Information
General Setup	
?E ?ECHO	Returns the echo setting n = 1 On n = 0 Off
?PROMPT ?>	Returns the prompt setting n = 1 On n = 0 Off
?EOT	Query state of end of text character n = 1 Enable n = 0 Disable
Laser Operation	
PRINT LASER ?L ?LASER	Returns status of the laser soft key state 0 = Off (standby) 1 = On
PRINT KEYSWITCH ?K	Returns status of the keyswitch 0 = Off 1 = On
PRINT TUNING STATUS ?TS	Returns the tuning status 0 = Completed tune 1 = Tuning
?ST	Returns the current operating status string, such as "Tuning" or "OK".
?ALIGNFIXED	Returns the status of the fixed output alignment mode n = 1 Enabled n = 0 Disabled
?ALIGNVAR ?Align	Returns the status of the tunable output alignment mode n = 1 Enabled n = 0 Disabled
PRINT SHUTTER ?SVAR ?S	Returns the state of the tunable output external shutter 0 = Closed 1 = Open
?SFIXED	Returns the state of the fixed output external shutter n = 0 Closed n = 1 Open

Table 7-5. Chameleon Discovery Queries (Sheet 2 of 3)

Queries	Returned Information
PRINT WAVELENGTH ?VW ?WV	Returns the last commanded Chameleon wavelength, <i>nnn</i> , in nanometers
PRINT UF POWER ?PVAR ?UF	Query the power from the tunable output, in milliwatts
?PFIXED	Query the power from the fixed output, in milliwatts
?HB ?HEARTBEAT	Returns the status of the Heartbeat n = 1 Enabled n = 0 Disabled
?HBR ?HEARTBEATRATE	Queries the time-out period (between 1 to 100 seconds) of the Heartbeat rate for laser shut down in the absence of RS-232 activity.
Pre-compensator	
?GDDCURVE	Returns the current calibration curve by curve number
?GDDCURVEN	Returns the current curve by name
?GDD	Query current GDD setting Returns <i>yyyyy</i> where <i>yyyyy</i> is the GDD in fs ² or <i>yyyyy X</i> , where the character X denotes that the value has been extrapolated from limited calibration data
?CURVEN:x	Returns the name of current curve number x
?CURVEPT:ww=x	Query values of curve <i>ww</i> point x Returns: <i>zzzzz yyyy</i> where <i>zzzzz</i> is GDD, <i>yyyy</i> is wavelength
?CURVEPTGDD:x	Query GDD of current curve at point x
?CURVEPTW:	Query wavelength of current curve at point x
?CURVE:ww	Query calibration values for curve <i>ww</i> Returns array of calibration points x1 <i>yyyy1 zzzzz1</i> x2 <i>yyyy2 zzzzz2</i> x3 <i>yyyy3 zzzzz3</i> etc.
?GDDMAX	Returns the maximum GDD value available at the current wavelength
?GDDMIN	Returns the minimum GDD value available at the current wavelength
?GDDMAX:xxxx	Returns the maximum GDD value available at wavelength <i>xxxxnm</i>

Table 7-5. Chameleon Discovery Queries (Sheet 3 of 3)

Queries	Returned Information
?GDDMIN:xxxx	Returns the minimum GDD value available at wavelength xxxnm
Other	
?SN	Returns the Chameleon Discovery serial number
PRINT FAULTS ?F	Returns a list of number codes of all active faults
?FT ?FINFO	Return the active fault with text description
PRINT FAULT HISTORY ?FH ?FHIST	Returns a list of number codes of all the faults that have occurred since the last laser on command
?FHT	Return the historic fault with text description
?F:n	Return s description of system fault number 'n'

This Page Intentionally Left Blank

8 TPC Modulator Control

8.1 Introduction

The Discovery NX Total Power Control (TPC) has additional communication and control options to those of the base Discovery NX laser system, which were described in Section 4 and Section 7. This section details the connections and considerations required to control the modulators, which are only present in the TPC system. If it is not clear which mode of TPC operation should be selected, please consult Coherent Product Support. If the laser is not equipped with the TPC option, this section does not need to be consulted.

8.1.1 TPC Overview

The modulators comprise an AOM on each optical beamline (tunable and fixed), with each supplied RF electrical power from an individual RF driver. The RF drivers are integrated with the system and therefore are primarily controlled by the laser to achieve a user-defined attenuation level; however it is also possible to communicate directly with the RF drivers themselves using “Direct USB control,” as defined later in this chapter.

Whether controlling the RF drivers by sending commands to the laser system, or communicating directly with the RF drivers, the output optical power level can be modulated using an external analog signal voltage (10 V default, 5 V optional) applied to the back panel. All of these configurations and options are discussed in this chapter. The connections on the back panel will be referred to throughout this chapter and therefore a diagram of the laser head back panel is supplied below (Figure 8-1) and a corresponding table of connection protocol is supplied subsequently (Table 8-1).

8.1.2 Control Configuration

Each of the configurations is defined here, and these definitions correspond to the summary table (Table 8-1) and the back panel diagram (Figure 8-1).

The control configuration is chosen individually for each driver, using the prefix *aomt* for the tunable modulator and *aomf* for the fixed modulator. Laser (firmware) control is the default configuration, but toggling between

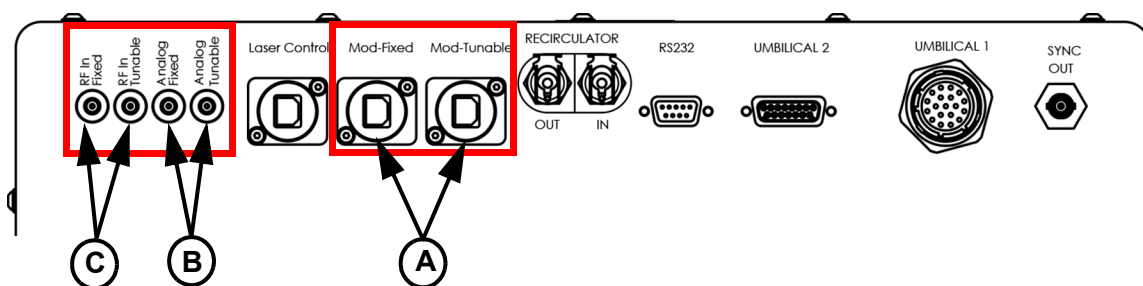

Figure 8-1. Discovery NX TPC Connection Locations

Table 8-1. TPC Connection Specification and Description

Connections	Specification	Description
Mod-Tunable (A)	USB type-B	Serial connection directly to the Tunable AOM driver
Mod-Fixed (A)	USB type-B	Serial connection directly to the Fixed (1040 nm) AOM driver
RF In Tunable (B)	SMA plug, 50 Ohm input impedance, maximum input < 2.5 W	RF input sent directly to the Tunable AOM
RF In Fixed (B)	SMA plug, 50 Ohm input impedance, maximum input < 2.5 W	RF input sent directly to the Fixed (1040 nm) AOM
Analog Tunable (C)	SMA plug, 10 kOhm input impedance, maximum input 10 Vdc ^a	0-10 Vdc ^a input to set/modulate Tunable laser power
Analog Fixed (C)	SMA plug, 10 kOhm input impedance, maximum input 10 Vdc ^a	0-10 Vdc ^a input to set/modulate Fixed laser power

a. The default voltage range is 0-10 V. This can be changed to 0-5 V. Contact Service for advice prior to changing the default.

Laser control (0) and Direct USB (1) can be toggled using the command `XXXXUSBCTRL=[0/1]`. Therefore setting the tunable modulator to laser control would require the command `"AOMTUSBCTRL=0"`. The command for setting the fixed modulator to Direct USB mode would be `"AOMFUSBCTRL=1"`.

8.1.2.1 Laser Control

This is the simplest method of controlling the modulators. The user needs only to communicate with the laser through the "Laser Control" serial port. The laser then processes the user's modulator serial commands to adjust the modulator settings accordingly. Laser commands for controlling the

modulators are listed in Table 8-2; note that each command is comprised of the prefix (AOMF or AOMT), which determines which beamline the instruction is applied to, and the command itself. Therefore, to switch the fixed modulator off, "AOMTON=0" would be used.

Table 8-2. Laser Serial Commands for Modulator Control

Prefix	Command	Description
All commands must have a prefix to designate the fixed or tunable modulator:	T	Change % Transmission (0-100%)
	USBCTRL	Direct USB/ Laser AOM control (1/0)
	ON	Switch Driver On/Off (1/0)
	EXTMODE	Enables external modulation mode (1/0)
AOMF (for fixed)	VMODE	See "External Modulation" for details on optical power control. Toggles between 0-10 V and 0-5 V range for analog voltage input. (0/1) ^a
AOMT (for tunable)		

a. **ATTENTION:** The system is shipped with the AOM drivers set with an input DC signal voltage range of 0-10 V (Vmode=1). Damage might occur if the selected voltage range is exceeded e.g. 10 V input when in 5 V mode (Vmode=0).

8.1.2.2 Direct USB (Legacy Mode)

Users who have already integrated the legacy Discovery TPC may prefer the NX TPC integration to match. To this end, Legacy Mode (Direct USB) is also possible. The consequence of using this mode is that communication with the modulators is separate, via the two additional modulator serial connections shown in Figure 8-1 (A) The port connection protocol is defined in Table 8-3.

Table 8-3. Port Description - AOM Driver

Parameter	Value
Data bits	8
Stop bits	1
Parity	none
Baud rate	57600

With the laser no longer handling the modulator settings, this must now be done at the user's control PC, using the Coherent Discovery GUI software, or a user-supplied equivalent. Whether using the Coherent GUI or another

control software solution, the so-called "AOM calibration file" (described in "Calibration for Direct USB (Legacy Mode) Modulator Control" (p. 57)) is required to translate the user's input modulation settings into AOM settings. A full description of control using the Coherent GUI is available in the Coherent Discovery GUI User's Guide (PN 1298356).

If using a software control solution other than the Coherent Discovery GUI, the modulators' drivers are controlled using the commands in Table 8-4. Note that these commands are not recognized by the laser and that laser commands are not recognized by the RF drivers.

Table 8-4. RF Driver Commands List^a

COMMAND	DESCRIPTION
F	RF electrical frequency Frequency adjust MHz, e.g. F89.253
P	RF electrical power Power adjust (digital 0-1023), e.g. P0346
D	Power adjust (dBm), e.g. D17.45
O	Switch on/off, e.g. O1 or O0
L	Fast channel control, e.g. L1Ffff.fffPppppDdd.ddOoliE where: L1 = channel selection Ffff.fff = frequency adjust (e.g. F102.347) Ppppp = power adjust (digital, e.g. P1017) Ddd.dd = power adjust (dBm, e.g. D17.45) Oo = switch on/off (1/0) li = internal mode on/off (1/0) E = immediate store
S	Status
I	Mode corresponds to external power modulation (1) or internal (2) Global lmode, e.g. I1 or I0 (1=external, 0=internal)
E	Store all channels data for selected profile+sweeping
V	Global Vmode, e.g. V1 or V0 (1=10V, 0=5V) ^b

a. These commands are specific to the AOM's driver and can be sent directly to the drivers using a terminal window. These commands are not recognized by the laser system or the Coherent GUI.

b. **ATTENTION:** The system is shipped with the AOM drivers set with an input DC signal voltage range of 0-10 V (Vmode=1). Damage might occur if the selected voltage range is exceeded e.g. 10 V input when in 5 V mode (Vmode=0).

8.1.2.3

Direct RF

In this configuration, RF electrical power is fed from a user's own RF driver to the AOMs via the RF input connections on the back panel, as indicated in Table 8-1(C). For this configuration to be established, field service intervention is required. **DO NOT** attempt to supply RF power to the AOMs without a field service visit to configure the connections appropriately as this is not a default option and requires the customer to bypass the internal drivers. Consult Coherent Service if you have an interest in operating with this mode.

If the customer request that the on-board drivers be reconnected a further service visit would be required. If this intervention is requested, it is possible that the system *cannot* be reverted back to utilize the on-board RF drivers.



Note that the direct RF connections serve no purpose when using the on-board RF drivers.

8.1.3

Power Control

The TPC can be used to set a constant power defined through serial commands, or the power level can be controlled through a combination of an externally applied voltage to the “Analog input” of the corresponding beam (tunable or fixed) and serial command.

8.1.3.1

Software Power Control

The optical power level is set using serial commands. It is not possible to modulate quickly using serial commands alone and this method of power control is appropriate for setting a single, constant power level. Any externally applied voltage to the “analog mod in” ports will not affect the optical power level.

8.1.3.2 External Modulation

Using Laser Control or Direct USB, the user can modulate the transmission level using an external analog voltage (0-10 V) applied to the appropriate analog input on the back panel as indicated in Table 8-1(B). It is possible to modulate the power quickly and arbitrarily with this configuration.

It should be noted that the resultant output transmission is a convolution of both the software attenuation level and the external voltage applied to the external modulation in port. For example;

- If 50% transmission is chosen via software and 10 V (of a maximum 10 V) is applied to the modulation port, 50% power is released from the modulator.
- If 100% transmission is chosen via software and 5 V (of a maximum of 10 V) is applied to the modulation port, 50% power is also released from the modulator.
- If 50% transmission is chosen via software and 5 V (of a maximum of 10 V) is applied to the modulation port, 25% power is released from the modulator as output.

For the best performance, lower the power as much as is practical using serial commands and apply voltages in the upper range for power control (maximize signal-to-noise ratio of the analog signal).

A summary of the configurations and their associated connections and features is supplied below in Table 8-5 to assist in selecting and implementing that which is most suitable.

Table 8-5. Modulation Configuration Set-Up

		OPERATIONAL MODE		
		INTERNAL	EXTERNAL	DIRECT RF ^a
Connections Required	Laser	Y	Y	Y
	Mod-Tunable	If using Direct USB	If using Direct USB	
	Mod-Fixed	If using Direct USB	If using Direct USB	
	RF In Tunable			Y (Only use in this case)
	RF In Fixed			Y (Only use in this case)
	Analog Tunable		Y	
	Analog Fixed		Y	
Constant Set Power Level		Y	Y	
Modulation			Y	
Integrated AOM drivers used		Y	Y	
Coherent calibration files provided		Y	Y	Y
Coherent calibration files required		Optional (Yes for Direct USB) ^b	Optional (Yes for Direct USB) ^b	Optional ^b
Coherent GUI Software required		Optional	Optional	

a. It is noted that the Direct RF method requires a physical intervention from Coherent Service since the integrated AOM drivers are bypassed. Do not connect any RF signal to the “RF In” unless it is configured correctly.

b. A calibration file of RF powers/frequencies is provided by Coherent. While in Direct USB mode, the Coherent GUI or equivalent software utilizes this file to control the modulator settings. The end user can modify, re-format, or generate new calibrations according to their requirements, however, please read the rest of this section for further advice.

8.1.4 Calibration for Direct USB (Legacy Mode) Modulator Control

It is important to understand that any combination of transmission level at a given wavelength at a constant output angle corresponds to a specific set of RF electrical driver parameters for the AOM. Therefore the modulators need to be controlled at all times to ensure predictable results. In the “laser control” configuration, this is managed automatically by the laser and requires no further consideration. If however “Direct USB control” is used, this section should be consulted.

While the laser and end-user software, such as the Coherent GUI accept meaningful parameters such as optical transmission at set wavelength, the RF driver only accepts RF power and RF frequency. Therefore, a look-up table is required to translate required optical output parameters into RF settings for the driver, and the Discovery NX TPC is shipped with a collection of look-up tables referred to as the “Calibration File” for this purpose. The calibration file is provided in text format on a memory stick found in the accessory kit, and the 3 look-up tables that form the calibration file are defined in Table 8-6 below. The system-specific files are provided in “plug and play” format for use with the Coherent GUI or can be adapted to the needs of a user for their software integration.

For further support on this aspect of the Discovery TPC, contact your local Coherent representative.

Table 8-6. AOM Calibration Parameters

Parameter	Description	Graphic Example
RF Power - Tunable	RF Power v AOM Transmission v Wavelength	<p>Tunable RF Power vs Wavelength vs Transmission</p> <p>This graph plots Transmission (0 to 100) on the y-axis against AOM RF power (0 to Max) on the x-axis. Four curves represent different wavelengths: Wavelength A (yellow), Wavelength B (blue), Wavelength C (orange), and Wavelength D (grey). Each curve shows a characteristic sigmoidal shape, where transmission increases with RF power and reaches a plateau at different power levels for each wavelength.</p>
RF Frequency-Tunable	Optimal RF Frequency v Wavelength	<p>Tunable Wavelength vs RF Frequency</p> <p>This graph plots MHz (0 to 160) on the y-axis against wavelength (700 to 1300) on the x-axis. A single blue curve shows that as the wavelength increases, the optimal RF frequency decreases from approximately 140 MHz at 700 nm to about 75 MHz at 1300 nm.</p>
RF Power-Fixed	RF Power v AOM Transmission	<p>Fixed RF Power vs Transmission</p> <p>This graph plots Transmission (0 to 100) on the y-axis against AOM RF power (0 to Max) on the x-axis. A single yellow curve represents a fixed wavelength of 1040 nm, showing a sigmoidal relationship between RF power and transmission.</p>

9 Troubleshooting

9.1 Troubleshooting Guide

For troubleshooting, if there is no laser output, or if the tunable output beam pointing varies with wavelength see “No Laser Output” (p. 59) and “Beam Pointing Varies with Wavelength (TPC systems only)” (p. 60). For identifying and clearing faults, see “Fault Conditions” (p. 60).

9.1.1 No Laser Output

Table 9-1. No Laser Output

Possible Cause	Indicator	Corrective Action or Reference
Active fault	Fault LED or ?F does not return '0'	Check “Fault Conditions” (p. 60) for action
Main power not connected	Laser Emission LED is not lit	Check that the PSU power switch is ON and cables are connected correctly
Key switch is set to standby	Key switch on the PSU or query ?K returns '0'	Key switch on the main power supply
Soft Key is set to standby	Query ?L returns '0'	Send the command L=1
Shutters are closed	Shutter button LED's on the PSU are not lit and the command ?SVAR and ?SFIXED returns '0'	Press the desired shutter button on the PSU or send the command SVAR=1 (to open the tunable output shutter) or SFIXED=1 (to open the fixed output shutter).
TPC transmission is set to 0 %	The laser is running in OK status, power on LED is lit but no output	Change AOM level to desired % of full power level.
TPC is in the wrong mode	The laser is running in OK status, power on LED is lit but no output	Check that the desired operational mode is selected (internal/external)
TPC in external mode but no analog voltage supplied	The laser is running in OK status, power on LED is lit but no output	Check external voltage and connection to Analog Inputs
Connection lost to TPC drivers	The laser is running in OK status, power on LED is lit but no output	Open “Connections” dialog in Coherent GUI and check the COM ports are connected.

9.1.2 Beam Pointing Varies with Wavelength (TPC systems only)

Table 9-2. Beam Pointing Varies

Possible cause	Indicator	Corrective action or reference
Incorrect TPC calibration file is being used in external mode.	The pointing of the tunable beam varies with wavelength. Problem disappears when AOM control is set to internal mode.	Ensure that the AOM calibration file in-use is the one on the memory stick shipped with the system.

9.1.3 Fault Conditions

An fault condition is indicated by one of the following:

- Solid light on Fault Status LED at the PSU front panel
- The indicator on the GUI
- A query ?f returns any number other than zero

Some fault conditions can be cleared by following the procedures described in “External Interlock Condition” (p. 61) or “Any Other Fault” (p. 61). Before attempting these procedures it is recommended to record the numbers of the fault(s) present. To do so the procedure below should be followed:

- Send the command ?f
- If the reply is not “0” then record the number or sequence of numbers returned
- Either cycle the keyswitch or send the commands fc followed by l=1. This will attempt to clear the fault and restart the laser.
- If the fault reappears then send the commands fc followed by ?fh. This will return a table listing all recent faults that have occurred. Record a screenshot of this table.
- It is also useful to take note of any information about when the fault(s) occur (e.g. intermittently, all the time, only when performing a specific action) and anything that happened before the fault occurred.

9.1.3.1 External Interlock Condition

- Follow the procedure to record the fault numbers described in “Fault Conditions”.
- Key and Switch off the laser at the PSU. If there is an interlock circuit in place, replace with the Coherent-provided interlock defeat. Check that umbilical connections are secure.
- If issue resolved, check interlock circuit
- If issue persists, contact Coherent Service

9.1.3.2 Any Other Fault

- Follow the procedure to record the fault numbers described in “Fault Conditions”
- Key and switch off laser at the PSU
- Check that all connections are secure
- Check that the chiller:
 - Is running at 20°?
 - Has sufficient fluid?
 - Hoses are not impeding fluid flow?
- If fault persists, call Coherent Support

9.1.3.3 Contacting Coherent Service

In order to resolve your issue quickly, the following is useful to provide on first contact with Coherent Service:

- Laser serial number
- Fault history of the laser if fault codes have been appearing
- Any changes you had noticed to laser performance over time
- An INTERNET connection to a computer connected to the laser and the latest version of TeamViewer installed (this will allow our engineers to connect to the laser, allowing faster response times)

This Page Intentionally Left Blank

10 Maintenance



WARNING!

Do not open the laser head assembly. There are no user serviceable components or adjustments inside and there are hazardous levels of laser energy within the laser head. Opening the laser head or breaking the security stickers voids the warranty and can permanently damage the system.

10.1 Chiller Maintenance

Replace the CoolFlow coolant solution in the chiller every 6 months. Wear gloves during this operation to avoid introduction of organic materials.

10.1.1 Draining Chiller

1. Wearing gloves, key and power OFF the laser PSU and chiller.
2. Using a suitable container to catch the fluid, fit the male draining hose provided to drain fitting 'L' in Figure 8-2, then loosen the filling lid 'C' as defined in Figure 8-2. Do not remove the filling cap completely. Once liquid has finished pouring out, re-tighten the drain cap. The step is further illustrated in Figure 8-1.
3. The coolant must be drained from the laser head. Remove the hoses from the back of the laser head.
4. While directing the cut end of the draining hose connected to outlet securely into a suitable container for the old cooling fluid, fit the female draining hoses provided to the inlet and outlet ports on the laser head. Apply 0.1 MPa air-pressure to the draining hose connected to the inlet until the fluid has drained out.
5. When the fluid has finished emptying into the container, remove the draining hoses from the back of the laser head.



Figure 10-1. Chiller Drain

10.1.2

Refill Chiller

1. Wearing gloves and using funnel provided, fill with fresh CoolFlow IGE through filling spout 'C' level gauge D reads full. Replace filling cap
2. Fit hoses between laser head and chiller
3. Switch on chiller. The chiller will start, but will stop with a fault on the first attempt as the cooling channels in the head will drain the chiller reservoir below minimum level.
4. Top up cooling fluid in chiller as many times as is necessary until it runs without faulting.

Follow MSDS instructions to clean any spills of the coolant onto the laser system. Report contamination of the laser system with any other materials to Coherent for guidance. In general, clean the laser head and power supply unit with dry clean room wipes to remove any dust or particulate accumulation.

HECR008 / HECR010

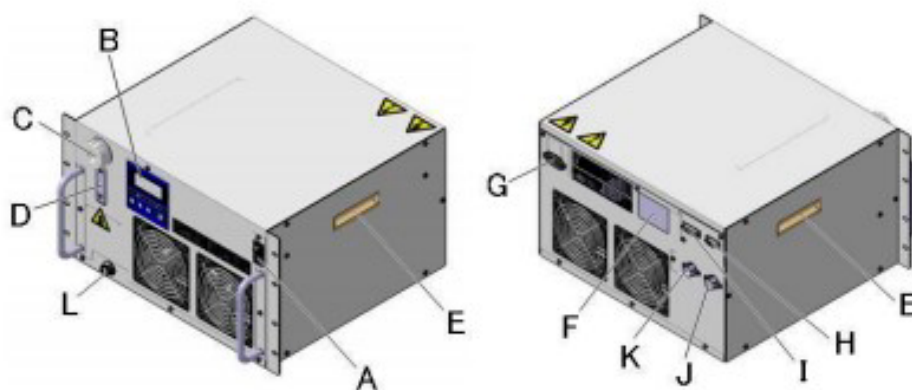

A	Power switch	G	Power supply connector
B	Display/Operation panel	H	Communication connector
C	Reservoir Cap	I	External sensor/Alam output connector
D	Level gauge	J	Circulating fluid OUT
E	Handle	K	Circulating fluid IN
F	Model No. label	L	Drain port

Figure 10-2. Chiller Diagram

This Page Intentionally Left Blank

11 Packing Procedure

11.1 Introduction

The Chameleon Discovery laser head weighs up to 98 kg, therefore safe lifting precautions should be adhered to while transporting the laser head.

The factory supplied packaging is adaptable to allow safe transportation of the laser head into or out of the crate. Removable handles are provided to assist in moving the laser head.



Figure 11-1. Removable Lifting Handles



CAUTION!
The Chameleon Discovery laser head weighs up to 98 kg, therefore safe lifting precautions should be adhered to while transporting the laser head.

11.2 Chameleon Discovery Crate

The Chameleon Discovery crate consists of the following:

1. Wooden crate with removable end and side panels for easy access.
2. Mobile trolley to rest the laser head on when situated in the crate and whilst being transported into or out of the crate.
3. Crate lid which can be doubled up as a ramp to allow the mobile trolley to be rolled into or out of the crate.
4. Foam packaging to protect the laser head.

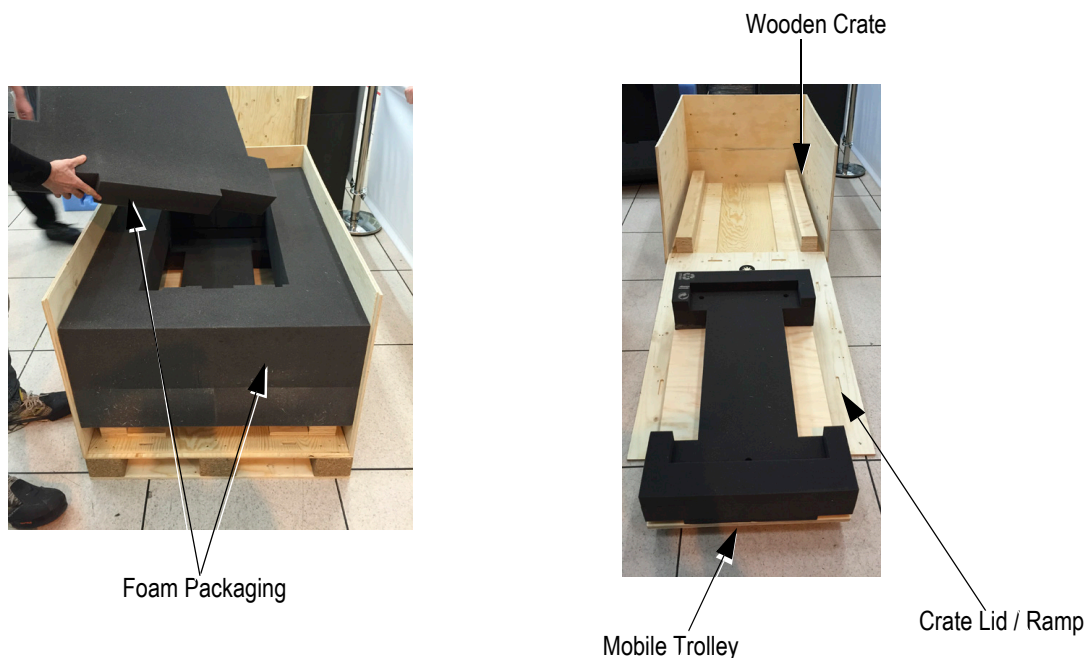

Figure 11-2. Chameleon Discovery Crate

11.3 Packaging the Discovery Laser Head

1. Remove excess coolant from the laser head. Place the laser head onto the mobile trolley while ensuring that the anti-static wrap is underneath.



NOTICE

Verify all four bolts are securely tightened in the lifting handles prior to moving or lifting the laser head.

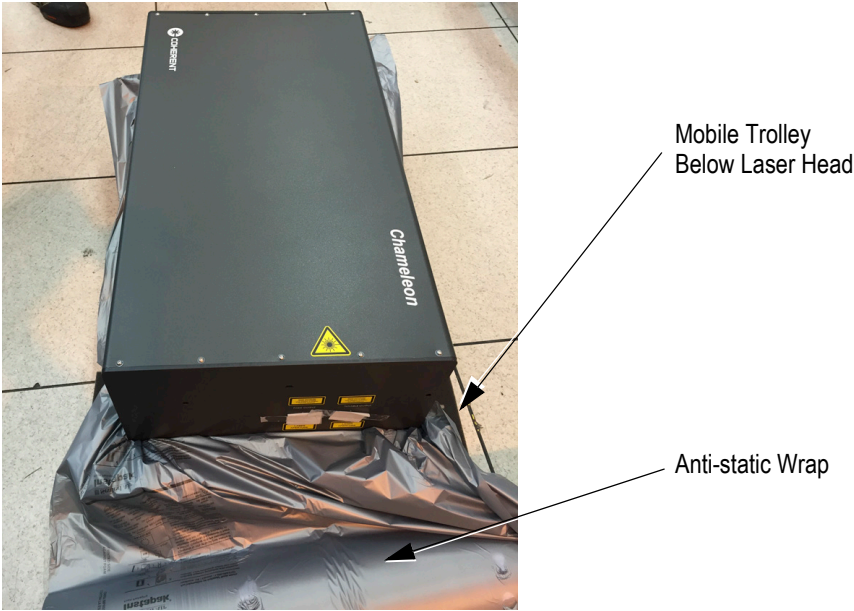

Figure 11-3. Placing Laser Head on Trolley

- 2. Cover the laser head with the anti-static wrap and fit the outer foam surround.

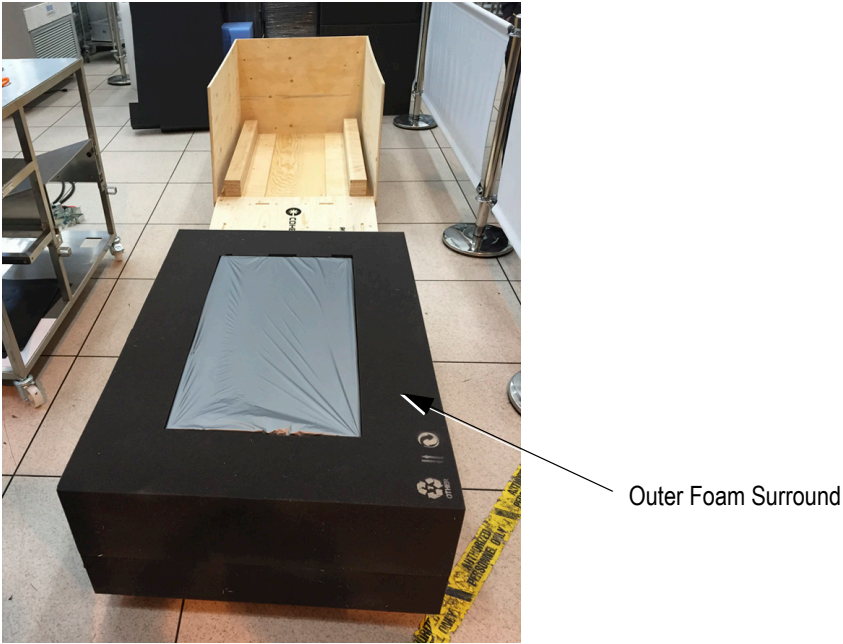

Figure 11-4. Covering the Laser Head

3. Use the crate lid as a ramp and push the laser head on the mobile trolley into the crate.

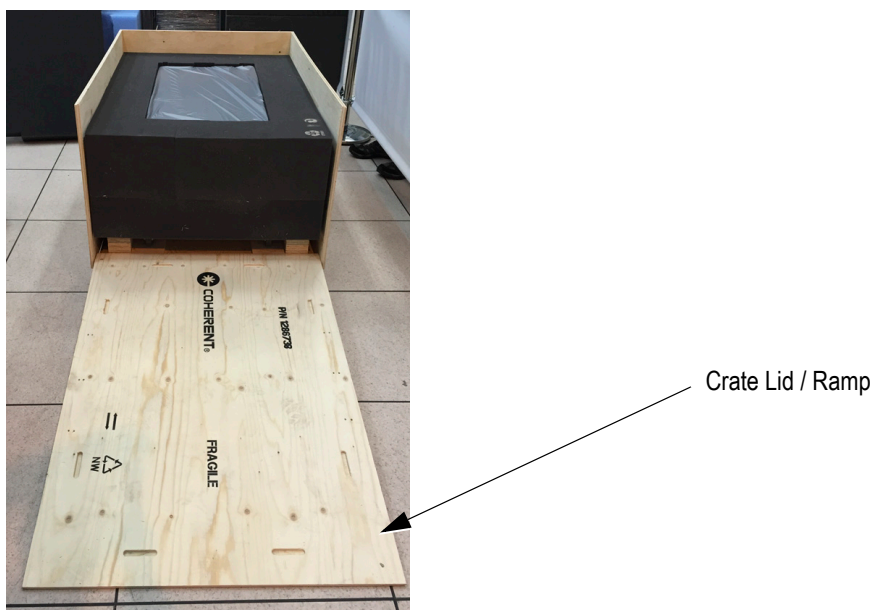

Figure 11-5. Pushing the Laser Head Into the Crate

4. Fit the crate end panel and fit the securing clamps.
5. Place the top foam section into the crate and fit the crate lid. Fit the securing clamps to secure the lid to the crate.

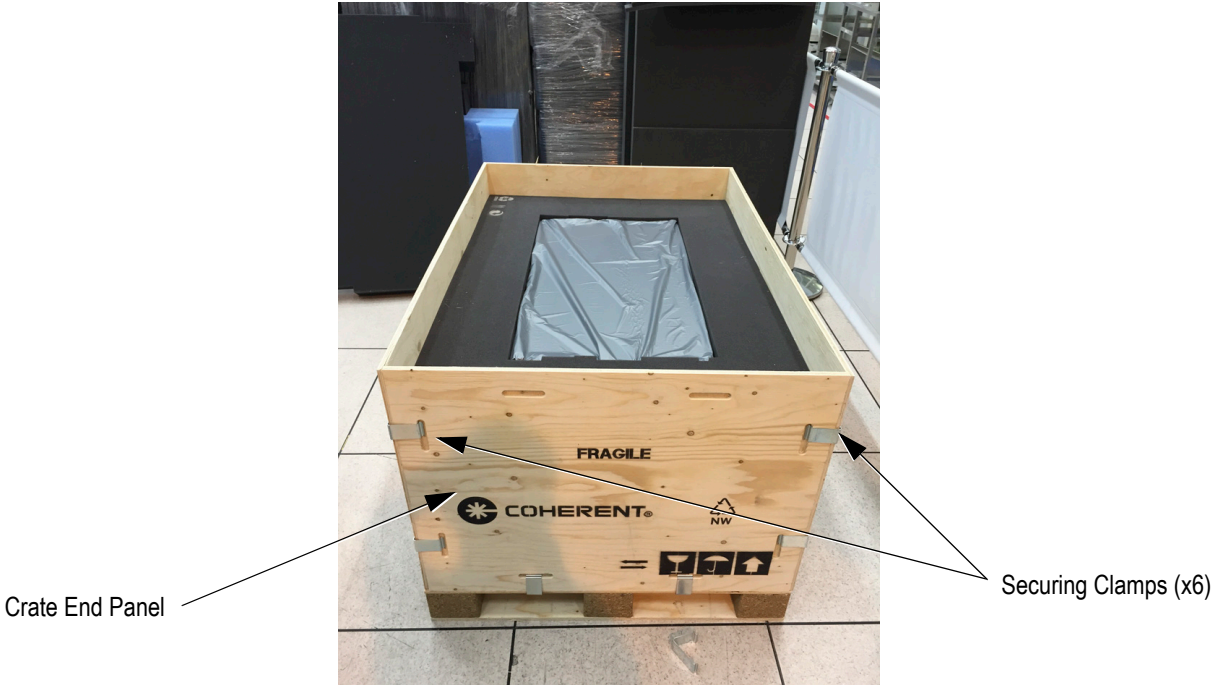

Figure 11-6. Securing Clamps

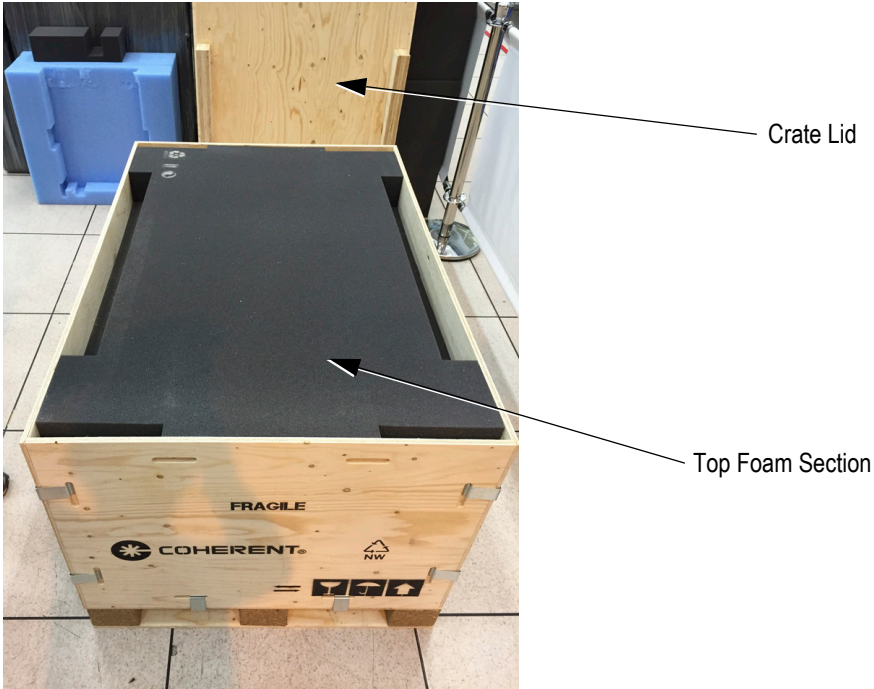

Figure 11-7. Fitting the Crate Lid

This Page Intentionally Left Blank

12 MRU X1

12.1 Description and Specifications

The Coherent miniature recirculator unit, the MRU X1, shown in Figure 12-1, is a stand-alone, 19" compatible rack mount unit designed to dry and filter air, then circulate it at atmospheric pressure and low flow rate. Clean dry air is sent to a sealed laser head to enable and maintain long-term reliable operation. A return line completes the air re-circulation back to the MRU X1.



Front View

Figure 12-1. Coherent MRU X1



Rear View

Figure 12-1. Coherent MRU X1

This unit was designed for use specifically in conjunction with Chameleon Discovery and standard Chameleon laser systems. It controls the humidity and cleanliness of the environment within the laser chamber to ensure long reliable operation of the optics and control mechanisms.

12.1.1

System Features

There are two filter stages within the MRU X1:

- The first stage removes moisture and molecular contaminants via a replaceable filter.
- The second stage is a 0.3 μm high-efficiency particulate air (HEPA) filter, removing any dust and debris emanating from the preceding filter stage.

The second filtration stage is designed for minimal user intervention and, depending on the ambient conditions, should last the lifetime of the Chameleon Discovery and standard Chameleon laser systems.

The air is circulated by means of a clean, oil-free diaphragm pump.

There are two interlock functions on the MRU X1. If for any reason these are open circuit, laser action is prevented:

1. **EXT. INTERLOCK** - This connects to a 4-pin HR-10 plug provided in the accessory kit. This can be used to connect the laser to another external interlock, such as a door for example, and replicates the orig-

inal function of the EXT. INTERLOCK on the back panel of the laser power supply.

2. **PSU INTERLOCK** - This connects the original EXT. INTERLOCK socket on the back of the laser power supply to the MRU X1 by a cable with 3-pin mini-DIN plugs, provided in the accessory kit.

12.1.2 System Specifications

Table 12-1. MRU X1 System Specifications

System Parameter	Specification
Dimensions	450 mm x 432 mm x 95 mm (17.8" x 17.0" x 3.7")
Weight	12 kg (26.5 lbs.)
Airflow Rate	1 to 2.5 L/min.
Maximum Continuous Pressure	1.4 bar (absolute)
Maximum End Vacuum	0.24 bar (absolute)
Voltage Input	100 to 240 VAC, 50/60 Hz
Fuse Rating	5 Amp (T5A L 250 V)
BNC Output	0 to 5 V, 1 M Ω
Interlock Circuit Rating	Normally open 12 VDC (dependent on laser circuit)
Interlock Impedance	< 0.2 Ω
Relative Humidity	5 to 95%
Operating Temperature	15° to 35°C (59° to 95°F)

12.2 Safety

The MRU X1 is a low-flow, low pressure device operating at around 3 to 5 psi and is an inherently safe device.

However, since it operates in conjunction with Class 4 laser systems, the appropriate laser manual safety procedures and government regulations pertaining to Class 4 laser emissions in laboratories must be enforced in the MRU X1 environment.

12.2.1 Chemical Safety

In normal operation, the user will not come into contact with the chemicals contained within the enclosed drying filter.

The chemical presents no risk to health, providing that the sealed container is not opened. There is no need to open the filter housing to replenish the contents since the filter must be exchanged as a complete module. Please refer to the Manufacture Safety Data Sheets (MSDS) for the filter material for further information. Please dispose of the drying filter in accordance with local government health and safety regulations.

12.2.2 Operating Controls

The MRU X1 has only one user-operated control. The ON/OFF switch on the back panel, which is part of the mains input power module. The switch turns the MRU X1 power on to activate the power supply, interlock PCB and the air pump.

12.2.3 Location of Safety Labels

There are seven labels, five of which are safety labels positioned on the rear panel of the MRU X1, and the remaining two being located inside the enclosure. The product nameplate label, the specified fuse rating label, the CE Mark label the EU/China RoHS symbols, and the Wheeled Bin label are located on the back panel to the left of the power entry module.

Inside the MRU X1 enclosure, the electrical hazard label is placed above the power supply on the protective shield and the earth label is beside an internal earth post.



Product Nameplate Label
located on rear panel

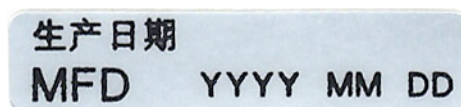

Manufacture Date Label
located on rear panel

Figure 12-2. MRU X1 Labels



Fuse Rating Label
located on rear panel



H.V. Warning Label
situated on protective
cover above power supply

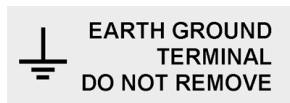

Earth Ground Label
situated beside the
earth terminal post



Certificate of Conformity Label
situated on rear panel



United Kingdom Conformity Assessed Label
situated on rear panel

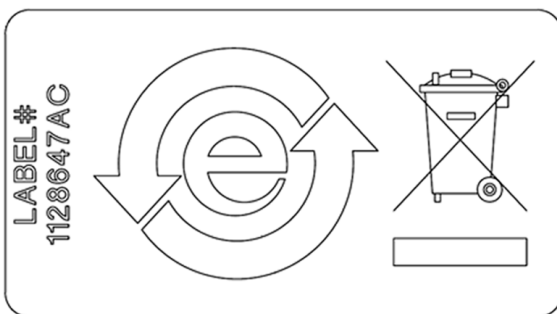

EU RoHS Wheel Bin and
China RoHS "e"
located on rear panel

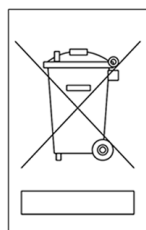

Wheeled Bin
located on rear panel

Figure 12-2. MRU X1 Labels (Continued)

12.2.4 Compliance with Government Requirements

Conforms to the relevant European Union harmonization legislation:

Directives:

2014/35/EU	Low Voltage Directive (LVD)
2014/30/EU	Electromagnetic Compatibility (EMC)
2011/65/EU	Restriction of the Use of Certain Hazardous Substances in Electrical and Electronic Equipment (RoHS-2)

Standards:

Safety:	EN 61010-1/IEC 61010-1: Safety requirements for measurement, control and laboratory use EN 60825-1/IEC 60825-1: Safety of Laser Products
EMC:	EN 61326-1/IEC 60825-1: Electrical Requirements for measurement, control and laboratory use
RoHS:	EN 63000/IEC 63000: Technical documentation for the assessment of electrical and electronic products with respect to the restriction of hazardous substances

Compliance of this Laser with the European requirements is certified by the CE mark.

12.3 Installation

12.3.1 Receiving and Inspection

On receipt of the MRU X1, remove it from its box and check that all parts are present and undamaged.

12.3.2 19" Rack Mounting Brackets

The MRU X1 can be mounted into a 19" rack by attaching the two brackets supplied in the accessory kit to the sides of the enclosure. The brackets are removed for shipping. There are four screws supplied to enable the brackets to be attached to the sides of the enclosure at the front using a 1/8" Allen (hex) key.

12.3.3 External Connections

Before making or breaking any electrical or air connections to the MRU X1, ensure that the system is switched off and that the laser has been switched to the STANDBY position. Refer to “System Turn-off” (p. 38) for laser operating instructions if necessary.

12.3.4 Air Connections

The MRU X1 comes ready-made with all necessary connectors and hoses. The hoses and fittings are color-coded to ensure the flow direction is correct.



NOTICE

The connectors for the MRU must not be contaminated during handling or set up. These ports provide a direct line to the laser head. If clean handling is not observed, contamination may work itself inside the laser head reducing the lifetime of the laser.

1. Connect the blue band hose quick-release connector to the MRU X1 OUT port (blue label) on the back of the MRU X1 system. This should be pushed home firmly until it clicks and locks in position.
2. Connect the other end of this blue band hose to the laser head IN port. Push the quick-release connector in firmly until it clicks and locks in position.
3. Connect the red band hose quick-release connector to the laser head OUT port (red label). This should be pushed home firmly until it clicks and locks in position.
4. In similar manner, connect the return red band hose from the laser head to the MRU X1 IN (red label) port on the MRU X1 system. This should be pushed in firmly until it clicks and locks in position.
5. Finally, confirm that the air flow direction is correct: MRU X1 OUT to laser head IN; laser head OUT to MRU X1 IN.



NOTICE

Different fitting types for air and water-cooling connection lines prevent accidentally or inadvertently connecting air lines to the water-cooling circuit or water-cooling lines to the air circuit. If using fittings different than original, make certain the air and water lines are not mixed up! Pumping water into the laser head air lines voids the warranty. Pumping water into the MRU X1 air lines voids the warranty.

12.3.5

Interlock Connections

It is essential to the safe and reliable operation of the MRU X1 that the interlock connection between the MRU X1 and the laser power supply is made correctly. Failure to do so could result in serious injury to personnel and could cause severe damage to the laser and invalidate the warranty.



The interlock system has been designed using different style connectors so that MRU X1 is the master interlock. The laser power supply interlock will not be satisfied unless the MRU X1 is powered on and the MRU X1 EXT interlock is closed (interlock override plug installed or customer provide switch or contact is closed). A customer constructed door interlock cable, using the provided HR10 connector, cannot be plugged into the power supply bypassing the MRU X1. The purpose of this design is to reduce the chance of the laser operating without a functional MRU X1.

1. Connect the PSU interlock cable supplied in the accessory kit to the PSU INTERLOCK socket on the back of the MRU X1 unit.
2. Connect the other end of this cable to the EXTERNAL INTERLOCK on the back of the Chameleon Discovery or standard Chameleon power supply.
3. Connect the external interlock over-ride plug supplied in the accessory kit to the EXT INTERLOCK on the back of the MRU X1 unit.



This external interlock must be satisfied by either the interlock override (interlock defeat) plug or via connection to a control switch, relay contacts or some other external safety device, such as a trip switch. If the interlock circuit is opened or broken in any way, the laser switches off immediately. When the break is rectified, the laser must be reset to clear the Interlock Fault.

Examples interlock circuits are shown in Figure 12-3.

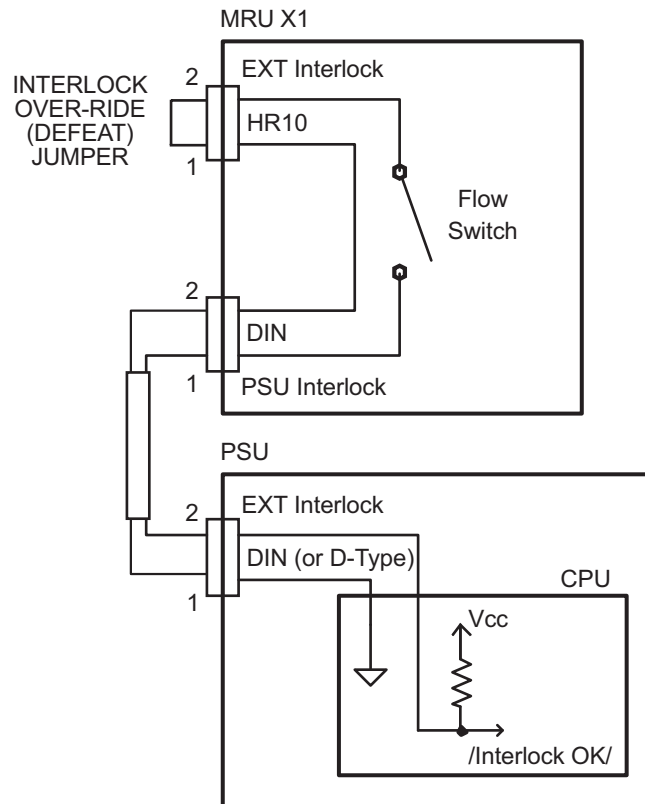

A. Interlock Circuit Over-ridden (defeated) by Jumper

Figure 12-3. Example Interlock Circuits

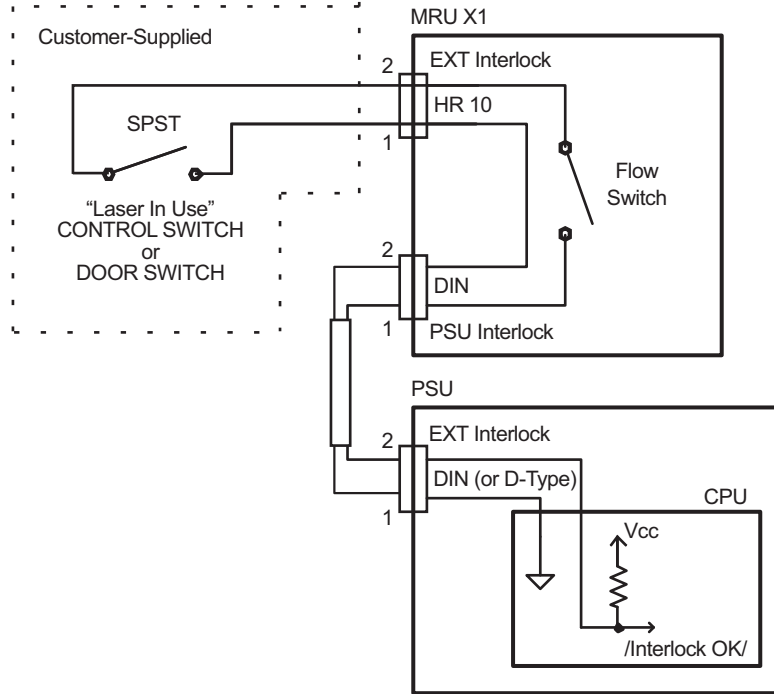

B. Interlock Circuit Satisfied by Closure of SPST Switch

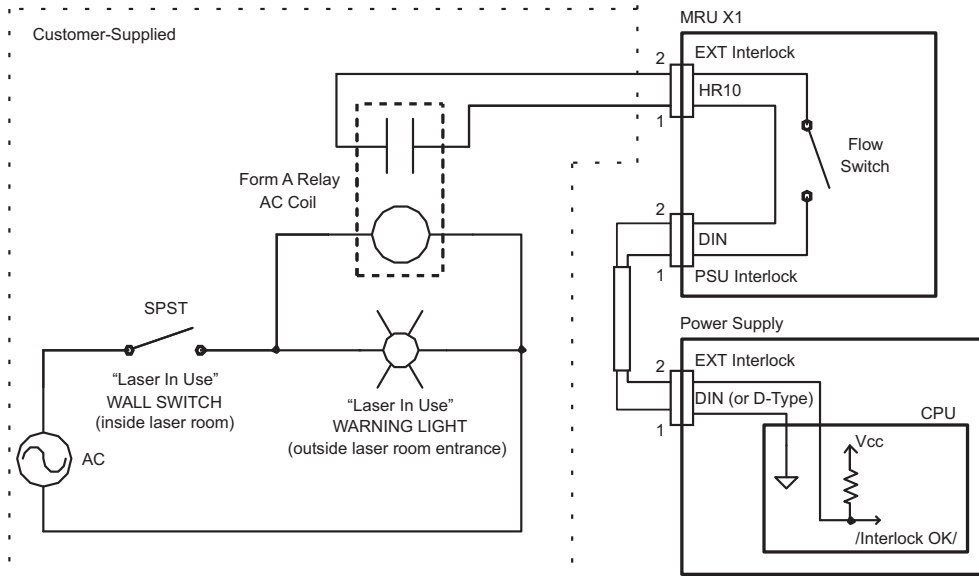

C. Interlock Circuit Satisfied by Closure of Relay Contacts; Relay Energized by "Laser In Use" SPST Switch

Figure 12-3. Example Interlock Circuits (Continued)

If the user has already constructed a door interlock cable that uses a connector style other than the HR10, the cable must be modified to use the HR10 style connector used on EXT connection on the MRU X1.

12.4 Controls and Indicators

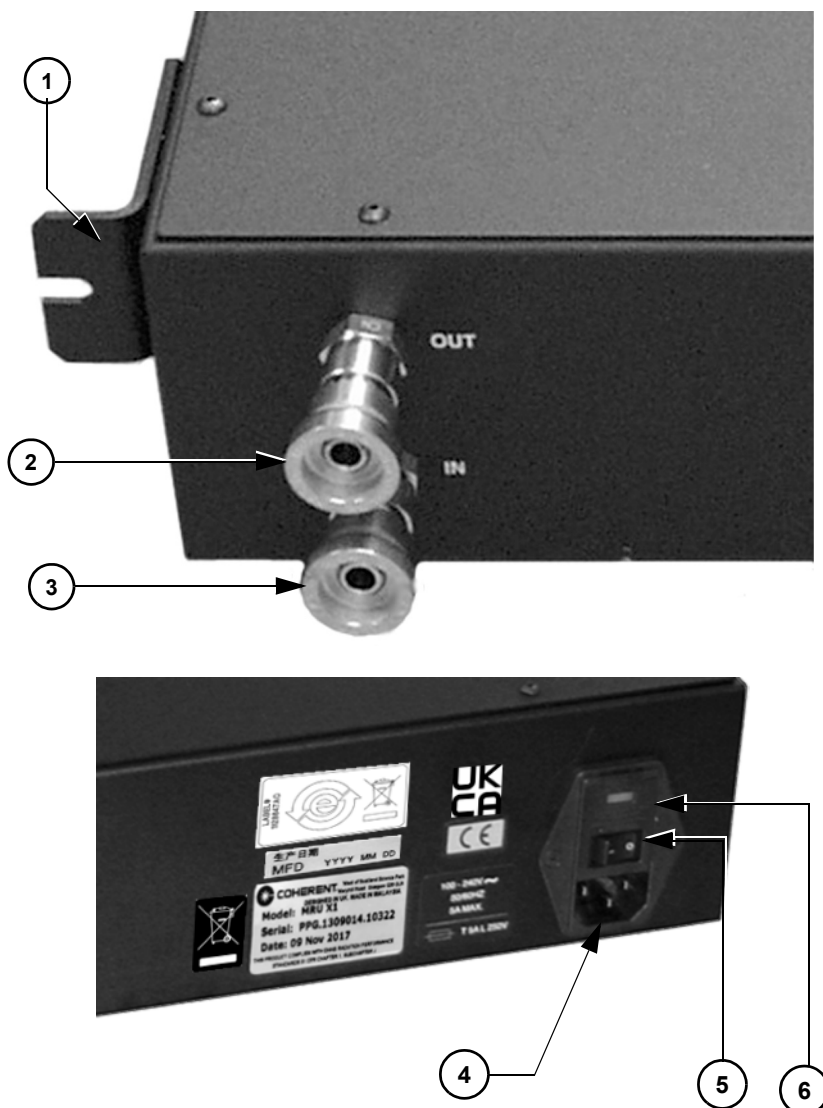

- | | |
|-----------------------------|-------------------------|
| 1. Rack mount | 4. Facility power input |
| 2. Air Flow "Out" connector | 5. Power switch and LED |
| 3. Air Flow "In" connector | 6. (Input) Fuse block |

Figure 12-4. MRU X1 Controls and Indicators

Table 12-2. MRU X1 Controls and Indicators

Item	Control	Function
1	Rack mount	Allows the MRU X1 to be installed in a standard laboratory mount. The length x width dimensions of the MRU X1 are 450 mm x 432 mm (17.8 x 17.0 in.).
2	Flow "Out" connector	Connects the output line flow to Chameleon Discovery and standard Chameleon laser head.
3	Flow "In" connector	Connects the return line flow from Chameleon Discovery and standard Chameleon laser head.
4	Power Cord input	The power input module provides cord connection of the MRU X1 to facility power. The internal power supply is auto-switching, 100 - 240 VAC 50/60 Hz.
5	Power Switch and LED	Turns the MRU X1 on. The LED in the power switch illuminates when the power is enabled. To assure the longest lifetime from the Chameleon Discovery and standard Chameleon laser system, the MRU X1 should be left on at all times. For additional information see "Turn-off (Daily Use)" (p. 38).
6	Fuse Block	Retains the mains input fuses, T 5A (x2)

12.4.1 Front Panel Indicator

The following sections highlight the controls, indicators and features located on the front panel of the MRU X1.

12.4.1.1 Power LED

An LED is provided to indicate whether the MRU X1 is powered. When powered on, the LED will glow bright green.

12.4.2 Rear Panel Controls and Indicators

The following sections highlight the controls, indicators and features located on the rear panel of the MRU X1.

12.4.2.1 Air In & Air Out Ports

The AIR OUT and AIR IN ports are Swagelock automatic shut-off type, such that when the connector is removed, the port seals itself. The fittings must be pushed quite firmly together until they "click" and lock home.

The air directionality must be followed on the MRU X1. The fittings are therefore color-coded blue for AIR OUT and red for AIR IN. See Figure 12-5.

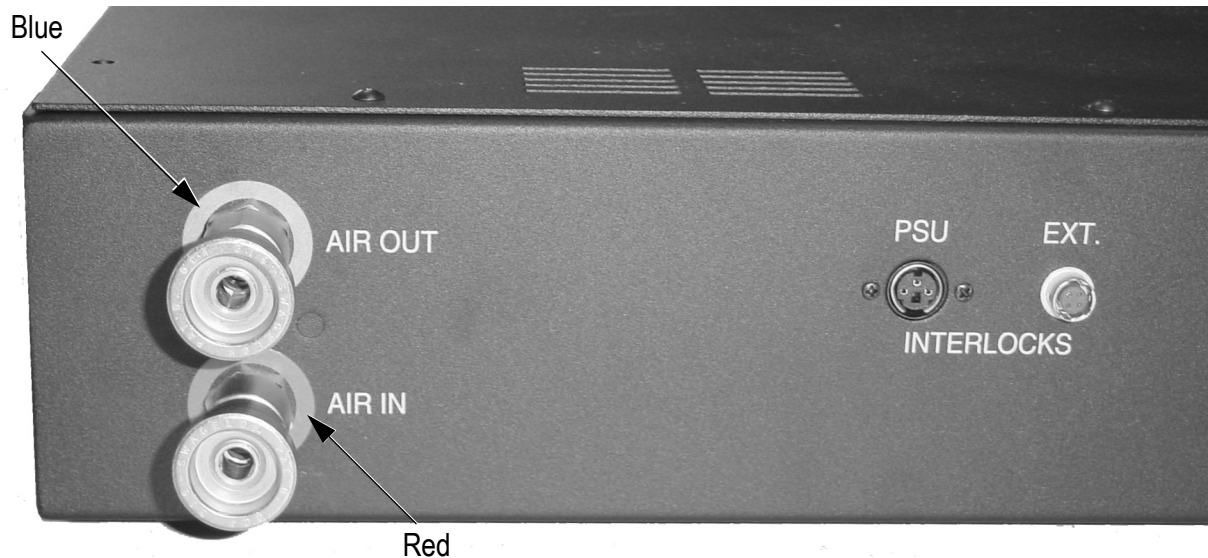

Figure 12-5. Air Ports and Laser Interlocks (Back of Unit)

12.4.2.2

Interlocks

Two interlock connections are provided on the rear panel - the PSU (power supply unit) interlock and the EXT (external) interlock. See Figure 12-5.

The PSU interlock connects the MRU X1 to the laser power supply interlock port using 3-pin mini-DIN type connectors on a 4 m length of cable. The EXT interlock connection must be closed, either by a shorted mating plug (interlock over-ride plug) or via an optional customer supplied door switch using a 4-pin HR10 type connector.

The PSU cable, an EXT interlock over-ride plug and a spare HR10 connector are provided in the MRU X1 accessory kit.

12.4.2.3

Mains Power Input

The MRU X1 has a universal mains power input beside the power switch on the rear panel. The fuse holder can be pulled out enabling the fuses to be checked. See Figure 12-6.



Figure 12-6. Mains Input Showing Fuse Access

12.5 Maintenance and Troubleshooting

The following section describes basic troubleshooting procedures which can help the user diagnose and correct many operational troubles with the MRU X1. If a particular problem cannot be resolved, or if a procedure calls for it, Coherent Service should be contacted via the appropriate authorized Coherent Service representative. Please have the following information ready for the Coherent Service representative:

- The model name and serial number of the Chameleon Discovery or standard Chameleon laser with which the MRU X1 is currently being used.

12.5.1 Maintenance

The MRU X1 requires only minimal maintenance intervention to verify the operation of the interlock circuit, to replace expired drying filters.

12.5.1.1 Interlock Circuit Checkout

On an annual basis (or more frequently if local regulations require), verify the interlock circuit is functional.

1. Place the Chameleon Discovery or standard Chameleon system in a normal operating mode.
2. Open (or remove) the EXT Interlock connection from the rear of the MRU X1 and verify the laser faults with an External Interlock error.
3. Close (or insert) the EXT Interlock connection to the rear of the MRU X1 and reset the Interlock fault.
4. With the laser again in a normal operating mode, turn off the MRU X1 power switch and verify the laser faults with an External Interlock error.
5. Turn MRU X1 power back on, reset the Interlock fault and verify the laser returns to normal operating mode.

12.5.1.2 Drying Filter

When the indicating band on the drying filter changes color to “depleted” as per the label on the drying filter, the filter must be replaced immediately. It is advisable to change the drying filter just prior to its depletion. It is not recommended to operate the MRU X1 or laser when the drying filter indicator band shows depleted.

12.5.1.2.1 Inspect/Change Drying Filter

The drying filter within the MRU X1 should be inspected for a color change, described above, on a 6 month schedule. However, if the MRU X1 is operated in very humid environments the frequency should be increased based on experience.

The laser must be in STANDBY when this activity is carried out. Otherwise, the MRU X1 interlock will cause the laser to shutdown when power to the MRU X1 is turned off or the filter housing is disconnected.

1. Key the laser to the STANDBY position.
2. Switch OFF the MRU X1 and disconnect the power cable.
3. Disconnect the external cooling tubes from the rear of the MRU X1.
4. Put protective dust caps on the tube ends to prevent contamination.
5. Remove the screws from the MRU X1 cover.
6. Lift the MRU X1 cover from the housing and store safely (a earth strap is attached between MRU X1 cover and inner housing).
7. Disconnect the tubes leading into the expired filter by the press-release method at the connections.
8. Remove the tie-wraps holding the filter in position.

9. Remove the expired filter from the clips.
10. Discard the expired filter as recommended in the MSDS.



Figure 12-7. MRU X1 Internal Components

11. Unpack new the filter and position in the clips.
12. Attach the tube connections at both ends of the filter.
13. Ensure the color band on the filter is visible.
14. Use the tie-wraps supplied with the new filter to hold the clips together at each end of the filter cylinder.
15. Ensure the tubes are not caught on any metal fittings.
16. Tighten the tie-wraps to secure the filter cylinder.
17. Check all the fitting connections to ensure they are correctly sealed.
18. Replace the MRU X1 cover to its original position and secure with the screws.
19. Remove dust covers from the external tube ends and reconnect the tubes to the correct location at the rear of the MRU X1.
20. Reconnect the power cable and switch ON the MRU X1.
21. Check that the MRU X1 is operational when the indicator light changes from red to green.

See "Parts List" (p. 113) to order spare part replacements for the MRU X1.

12.5.1.3 HEPA Filter Replacement

It is recommended to replace the HEPA filter every three years or 25,000 hours of operation, though effectively it lasts the life of the system.

12.5.1.4 Fuse Replacement

The following procedure outlines the replacement of the MRU X1 mains fuse(s).

1. Using a small, flat screwdriver lever, open the top catch and flip down the door above the mains input socket. Refer to Figure 12-6.
2. Then lever out and pull the red compartment holding the two fuses.
3. Remove the two fuses and check to see which is blown using a DVM.
4. Replace the blown fuse(s) with a 5 A (T5 A L 250 V) and slide the compartment back into place.
5. Replace the catch.

This Page Intentionally Left Blank

13 Calibration File Examples

13.1 Sample Calibration Files

13.1.1 Tunable RF Power vs Wavelength vs Transmission

	660	680	700	750	800	850	900	950	1000	1050	1100	1150	1200	1250	1300	1320
0	0	0	0	0	0	0	0	0	0	0	0	0	0	0	0	0
5	2.041	1.073	0.861	0.694	0.73	0.737	0.608	0.66	0.586	0.534	0.559	0.516	0.44	0.438	0.457	0.415
10	3.364	2.459	2.144	1.742	1.696	1.629	1.456	1.328	1.138	1.07	0.96	0.91	0.825	0.802	0.708	0.717
15	8.108	6.948	6.125	4.997	4.849	4.612	4.113	3.63	3.282	2.96	2.665	2.508	2.283	2.155	1.997	1.831
17.5	13.287	11.849	10.468	8.689	8.287	7.848	7.027	6.214	5.605	5.077	4.589	4.33	3.959	3.645	3.362	3.184
20	22.298	20.136	17.983	15.059	14.391	13.625	12.133	10.809	9.693	8.826	8.112	7.519	6.826	6.294	5.787	5.506
21	27.225	24.829	22.258	18.695	17.869	16.957	15.194	13.484	12.079	10.957	10.167	9.395	8.578	7.925	7.279	6.873
22	33.454	30.604	27.536	23.225	22.231	21.14	18.958	16.905	15.125	13.781	12.741	11.741	10.744	9.958	9.168	8.665
23	40.829	37.814	34.123	28.927	27.688	26.415	23.689	21.124	18.99	17.344	16.056	14.9	13.563	12.53	11.531	10.949
24	49.167	45.418	41.412	35.406	33.903	32.37	29.173	25.987	23.485	21.52	19.899	18.483	16.867	15.639	14.381	13.678
25	58.953	55.048	50.285	43.303	41.607	39.771	35.99	32.276	29.176	26.821	24.83	23.129	21.152	19.554	18.062	17.162
26	69.142	65.086	59.948	52.161	50.312	48.281	43.854	39.436	35.805	32.975	30.682	28.635	26.206	24.321	22.407	21.465
26.5	74.16	70.079	64.737	56.781	54.824	52.688	47.96	43.319	39.388	36.319	33.933	31.624	29.023	26.959	24.863	23.789
27	79.647	75.966	70.477	62.351	60.293	58.071	53.021	47.902	43.838	40.525	37.945	35.395	32.568	30.252	28.016	26.768
27.5	84.919	81.3	75.914	67.595	65.587	63.179	58.033	52.566	48.245	44.766	41.976	39.176	36.153	33.631	31.215	29.921
28	89.214	85.642	80.742	72.413	70.392	67.895	62.49	57.08	52.451	48.744	45.894	42.952	39.7	36.953	34.306	32.886
28.5	93.469	90.558	85.863	78.018	75.944	73.533	67.991	62.317	57.592	53.749	50.636	47.577	43.989	41.106	38.286	36.668
29	96.603	94.439	90.576	83.174	81.141	78.754	73.242	67.469	62.546	58.703	55.393	52.211	48.462	45.267	42.354	40.568
29.5	99.097	97.81	94.537	88.223	86.417	84.115	78.721	72.887	68.032	64.077	60.778	57.259	53.525	50.057	46.969	45.116
30	100	99.734	97.689	92.531	90.996	88.927	83.677	78.04	73.356	69.468	65.97	62.583	58.554	54.893	51.804	49.782
30.5	99.245	100	99.67	96.148	94.88	93.173	88.542	83.189	78.772	74.825	71.481	68.175	64.058	60.288	56.969	54.952
31	96.558	98.826	100	98.662	97.782	96.468	92.523	87.736	83.661	79.995	76.813	73.385	69.477	65.544	62.277	60.169
31.5	91.692	95.805	98.793	100	99.648	98.929	95.884	91.741	88.341	85.148	81.967	78.984	75.126	71.233	68.044	65.714
32	84.865	90.517	95.642	99.819	100	100	98.407	95.235	92.429	89.733	87	84.288	80.732	76.903	73.924	71.641
32.5	75.906	82.88	90.316	97.783	98.725	99.861	99.708	97.991	95.996	93.806	91.591	89.105	86.142	82.636	79.985	77.915
32.8	69.292	76.712	85.577	95.219	96.736	98.651	100	99.126	97.789	96.068	94.253	92.228	89.706	86.654	84.307	82.403
33	64.483	71.977	81.881	92.973	95.144	97.543	99.846	99.588	98.776	97.418	95.905	93.909	91.814	89.132	87.098	85.484
33.3	57.299	64.947	75.797	89.119	92.038	95.519	99.327	99.894	99.707	98.614	97.492	96.039	94.561	92.591	91.073	89.623
33.5	52.474	59.91	71.246	86.084	89.503	93.59	98.718	100	99.858	99.41	98.569	97.561	96.225	94.76	93.712	92.592
33.8	45.133	51.832	63.709	80.431	84.992	90.414	97.153	99.479	100	99.887	99.484	99.187	98.469	97.878	97.339	96.684
34	40.817	46.831	58.889	76.484	81.88	88.063	95.956	98.976	99.822	100	99.865	99.934	99.651	99.535	99.473	98.992
34.1	39.242	44.906	56.908	74.804	80.596	87.189	95.481	98.8	99.675	99.999	100	100	100	100	100	100

13.1.2 Tunable Wavelength vs RF Frequency

660	147.728			1278	77.321	
661	147.248			1279	77.266	
662	146.768			1280	77.211	
663	146.288			1281	77.147	
664	145.808			1282	77.082	
665	145.328			1283	77.018	
666	145.111			1284	76.953	
667	144.893			1285	76.889	
668	144.676			1286	76.824	
669	144.458			1287	76.76	
670	144.24			1288	76.695	
671	144.155			1289	76.631	
672	144.07			1290	76.566	
673	143.984			1291	76.492	
674	143.899			1292	76.418	
675	143.813			1293	76.343	
676	143.76			1294	76.269	
677	143.707			1295	76.194	
678	143.654			1296	76.13	
679	143.601	→	and so on	→	1297	76.066
680	143.548			1298	76.001	
681	143.437			1299	75.937	
682	143.326			1300	75.873	
683	143.215			1301	75.828	
684	143.104			1302	75.784	
685	142.993			1303	75.74	
686	142.804			1304	75.696	
687	142.615			1305	75.651	
688	142.426			1306	75.577	
689	142.237			1307	75.503	
690	142.048			1308	75.428	
691	141.842			1309	75.354	
692	141.635			1310	75.28	
693	141.428			1311	75.246	
694	141.222			1312	75.211	
695	141.015			1313	75.177	
696	140.81			1314	75.143	
697	140.606			1315	75.109	
698	140.401			1316	75.054	
699	140.197			1317	75	
700	139.992			1318	74.946	
701	139.83			1319	74.891	
702	139.667			1320	74.837	

13.1.3 Fixed RF Power vs Transmission

0	0
5	0.889
10	1.17
15	2.97
17.5	5.06
20	8.735
21	10.908
22	13.63
23	17.104
24	21.305
25	26.442
26	32.739
26.5	36.531
27	39.954
27.5	44.237
28	48.975
28.5	53.544
29	58.198
29.5	63.678
30	68.99
30.5	74.014
31	79.177
31.5	84.656
32	89.548
32.5	94.007
32.8	95.848
33	97.389
33.3	98.652
33.5	99.232
33.8	99.826
34	99.959
34.1	100

This Page Intentionally Left Blank

Appendix I: Laser Safety

This user information is in compliance with the following standards for Light-Emitting Products IEC 60825-1/EN 60825-1 “*Safety of laser products - Part 1: Equipment classification and requirements*” 21 CFR Title 21 Chapter 1, Subchapter J, Part 1040 “*Performance standards for light-emitting products*” except for conformance with IEC 60825-1 Ed. 3 and IEC 60601-2-22 Ed. 3.1, as described in Laser Notice No. 56, dated May 8, 2019.



WARNING!

VISIBLE AND INVISIBLE LASER RADIATION - AVOID EYE OR SKIN EXPOSURE TO DIRECT OR SCATTERED RADIATION CLASS 4 LASER PRODUCT!



WARNING!

Use of controls or adjustments or performance of procedures other than those specified herein may result in hazardous radiation exposure.

This laser safety section must be reviewed thoroughly prior to operating the Chameleon Discovery NX system. Safety instructions presented throughout this manual must be followed carefully.

I.1

Hazards

Hazards associated with lasers generally fall into the following categories:

- Biological hazards from exposure to laser radiation that may damage the eyes or skin
- Electrical hazards generated in the laser power supply or associated circuits

- Chemical hazards resulting from contact of the laser beam with volatile or flammable substances, or released as a result of laser material processing

The above list is not intended to be exhaustive. Anyone operating the laser must consider the interaction of the laser system with its specific working environment to identify potential hazards.

I.1.1 Optical Safety

Laser light, because of its optical qualities, poses safety hazards not associated with light from conventional light sources. The safe use of lasers requires all operators, and everyone near the laser system, to be aware of the dangers involved. Users must be familiar with the instrument and the properties of coherent, intense beams of light.

The safety precautions listed below are to be read and observed by anyone working with or near the laser. At all times, ensure that all personnel who operate, maintain or service the laser are protected from accidental or unnecessary exposure to laser radiation exceeding the accessible emission limits defined in the laser safety standards.



WARNING!

Direct eye contact with the output beam from the laser may cause serious eye injury and possible blindness.

The greatest concern when using a laser is eye safety. In addition to the main beam, there are often many smaller beams present at various angles near the laser system. These beams are formed by specular reflections of the main beam at polished surfaces such as lenses or beamsplitters. While weaker than the main beam, such beams may still be sufficiently intense to cause eye damage.

Laser beams are powerful enough to burn skin, clothing, or combustible materials, even at some distance. They can ignite volatile substances such as alcohol, gasoline, ether, and other solvents, and can damage light-sensitive elements in video cameras, photomultipliers, and photodiodes. The user is advised to follow the control measures below.

I.1.1.1

Recommended Precautions and Guidelines

1. Observe all safety precautions in the preinstallation and operator's manuals.
2. Always wear appropriate eyewear for protection against the specific wavelengths and laser energy being generated. See "Laser Safety Eyewear" (p. 97) for additional information.
3. Avoid wearing watches, jewelry, or other objects that may reflect or scatter the laser beam.
4. Stay aware of the laser beam path, particularly when external optics are used to steer the beam.
5. Provide enclosures for beam paths whenever possible.
6. Use appropriate energy-absorbing targets for beam blocking.
7. Block the beam before applying tools such as Allen wrenches or ball drivers to external optics.
8. Limit access to the laser to trained and qualified users who are familiar with laser safety practices. When not in use, lasers should be shut down completely and made off-limits to unauthorized personnel.
9. Terminate the laser beam with a light-absorbing material. Laser light can remain collimated over long distances and therefore presents a potential hazard if not confined. It is good practice to operate the laser in an enclosed room.
10. Post laser warning signs in the area of the laser beam to alert those present.
11. Exercise extreme caution when using solvents in the area of the laser.
12. Never look directly into the laser light source or at scattered laser light from any reflective surface, even when wearing laser safety eyewear. Never sight down the beam.
13. Set up the laser so that the beam height is either well below or well above eye level.
14. Avoid direct exposure to the laser light. Laser beams can easily cause flesh burns or ignite clothing.
15. Advise all those working with or near the laser of these precautions.

I.1.1.2

Laser Safety Eyewear

Always wear appropriate laser safety eyewear for protection against the specific wavelengths and laser energy being generated. The appropriate eye protection can be calculated as defined in the "EN 207 Personal eye

protection equipment - Filters and eye-protectors against laser radiation (laser eye-protectors)", in other national or international standards (e.g. ANSI, ACGIH, or OSHA) or as defined in national safety requirements.



CAUTION!

Laser safety eyewear protects the user from accidental exposure to laser radiation by blocking light at the laser wavelengths. However, laser safety eyewear may also prevent the operator from seeing the beam or the beam spot. Exercise extreme caution even while wearing safety glasses.

The Chameleon Discovery laser system produces optical power levels that are dangerous to the eyes and skin if exposed directly or indirectly. This product must be operated only with proper eye and skin protection at all times. Never view directly emitted or scattered radiation with unprotected eyes. Avoid direct viewing into the laser beam even while wearing sufficient eye protection.

I.1.2

Electrical Safety

Chameleon Discovery NX NX uses AC and DC voltages. There are no user serviceable components in the controller or laser head. All units are designed to be operated as assembled. Warranty will be voided if the laser head, the controller, or the cable is disassembled.



DANGER!

Normal operation of the Chameleon Discovery NX should not require access to the power supply circuitry. Removing the power supply cover will expose the user to potentially lethal electrical hazards. Contact an authorized service representative before attempting to correct any problem with the power supply.

I.1.2.1

Recommended Precautions and Guidelines

The following precautions must be observed by everyone when working with potentially hazardous electrical circuitry:

**DANGER!**

When working with electrical power systems, the rules for electrical safety must be strictly followed. Failure to do so could result in the exposure to lethal levels of electricity.

1. Disconnect main power lines before working on any electrical equipment when it is not necessary for the equipment to be operating.
2. Do not short or ground the power supply output. Protection against possible hazards requires proper connection of the ground terminal on the power cable, and an adequate external ground. Check these connections at the time of installation, and periodically thereafter.
3. Never work on electrical equipment unless there is another person nearby who is familiar with the operation and hazards of the equipment, and who is competent to administer first aid.
4. When possible, keep one hand away from the equipment to reduce the danger of current flowing through the body if a live circuit is touched accidentally.
5. Always use approved, insulated tools.
6. Special measurement techniques are required for this system. A technician who has a complete understanding of the system operation and associated electronics must select ground references.

I.2 Maximum Accessible Radiation Level

The Chameleon Discovery NX laser produces visible and invisible radiation over a wavelength range of 600 to 1400 nm, with a maximum average power of 16 Watts (maximum average power 8 Watts and pulse energy of 100 nJ per output aperture), pulse duration of > 50 femtoseconds, full angle divergence of 0.8 mrad to 1.7 mrad, and a repetition rate of 80 MHz [CFR 1040.10 (h)(1)(ii)].

I.3 Safety Features and Compliance with Government Requirements

The following features are incorporated into the instrument to conform to several government requirements:

United States of America:

The applicable United States Government requirements are contained in 21 CFR, Subchapter J, Part 1040, and in Laser Notice No. 56, dated

May 8, 2019, administered by the Center for Devices and Radiological Health (CDRH).

Europe:

The European Community requirements for product safety are specified in the Low Voltage Directive (LVD) (published in 2014/35/EU). The Low Voltage Directive requires that lasers comply with the standard EN 61010-1/IEC 61010-1 "Safety Requirements For Electrical Equipment For Measurement, Control and Laboratory Use" and EN 60825-1/IEC 60825-1 "Safety of Laser Products". Compliance of this laser with the European requirements is certified by the CE mark.

I.3.1 Laser Classification

Governmental standards and requirements specify that the laser must be classified according to the output power or energy and the laser wavelength. The Chameleon Discovery NX NX and NX TPC are classified as Class 4 based on 21 CFR, Subchapter J, Part 1040, section 1040.10 (c) and IEC/EN 60825-1. In this manual, the classification will be referred to as Class 4.

I.3.2 Protective Housing

The laser head is enclosed in a protective housing that prevents human access to radiation in excess of the limits of Class 1 radiation as specified in the 21CFR, Part 1040 Section 1040.10 (f)(1) and EN 60825-1/IEC 60825-1 except for the output beam, which is Class 4.

I.3.3 Remote Interlock Connector

The Chameleon Discovery laser system is equipped with an external interlock connector on the rear of the power supply. There are two pairs of terminals that must be electrically joined for the laser to operate [CFR 1040.10 (f)(3)].

I.3.4 Key Control

Operation of the Chameleon Discovery NX requires that the power supply keyswitch be in the ON position. The key is removable and the system cannot be operated when the key is removed [CFR 1040.10 (f)(4)].

I.3.5 Laser Radiation Emission Indicators

The LASER EMISSION indicators on both the power supply and the laser head illuminate approximately 30 seconds before laser emission can occur. The indicators are visible without exposing the operator to laser emission. Amber lights are used which are visible while wearing the proper type of safety glasses [CFR 1040.10(f)(5)].

I.3.6 Beam Attenuator

An internal shutter prevents exposure to all laser radiation without removing power from the system [CFR 1040.10 (f)(6)].

I.3.7 Operating Controls

The laser controls are positioned so that the operator is not exposed to laser emission while manipulating the controls [CFR 1040.10(f)(7)].

I.3.8 Manual Reset Mechanism

Following an interlock fault or unexpected loss of electrical power, laser operation cannot be resumed without activating either shutter [CFR 1040.10(f)(10)].



WARNING!

Use of controls or adjustments or performance of procedures other than those specified in this manual may result in hazardous radiation exposure.



NOTICE

Use of the system in a manner other than that described within this manual may impair the protection provided by the system.

I.4 Electromagnetic Compatibility

The European Community requirements for Electromagnetic Compliance are specified in the Electromagnetic Compatibility (EMC) Directive 2014/30/EU. Conformance to the EMC requirements is achieved through compliance with EN 61326-1/IEC 61326-1 (Electrical Requirements for measurement, control and laboratory use). Compliance of this Laser with the European requirements is certified by the CE mark.

I.5 Environmental Compliance

I.5.1 RoHS Compliance

The European Union RoHS Directive 2011/65/EU restricts the use of certain hazardous substances in electrical and electronic equipment. Coherent is in compliance with this Directive and can provide RoHS certification upon request.

Compliance of this Laser with the European requirements is certified by the CE mark.

I.5.2 China-RoHS Compliance



This section details compliance with the China RoHS (Restriction of Hazardous Substances) Regulation SJ/T 11364-2014.

This Regulation restricts the use of certain hazardous substances in electrical and electronic equipment. The China RoHS Regulation applies to the production, sale, and import of products into the Peoples Republic of China.

- Any hazardous substances in the Chameleon Discovery NX laser systems are listed in the table.
- The environmental-friendly use period is 20 years as indicated by the number 20 inside the circle.

The China RoHS Regulation also requires that the date of manufacture be identified (in Chinese characters) on the product label.

Table I-1. China-RoHS Compliant Components

PN: 1260938rAG		产品中有害物质的名称及含量					 
部件名称 Part Name	有害物质 Hazardous Substances						
	铅 (Pb)	汞 (Hg)	镉 (Cd)	六价铬 (Cr(VI))	多溴联苯 (PBB)	多溴二苯醚 (PBDE)	
印刷电路板组装 Printed Circuit Board Assembly	X	O	O	O	O	O	
电缆装配 Cable Assembly	O	O	X	O	O	O	
光学部件装配 Optic Assembly	X	O	O	O	O	O	
钣金组装 Sheet Metal Assembly	O	O	O	O	O	O	
电源 Power Supply	X	O	O	O	O	O	
组装二极管激光器 Laser Diode Assembly	O	O	O	O	O	O	
本表格依据 SJ/T 11364 的规定编制 O: 表示该有害物质在该部件所有均质材料中的含量均在 GB/T 26572 规定的限量要求以下。 X: 表示该有害物质至少在该部件的某一均质材料中的含量超出 GB/T 26572 规定的限量要求。							

I.5.3

EU REACH

REACH (Registration, Evaluation, Authorization and Restriction of Chemicals) is a European Union Commission (EUC) Regulation on chemicals and their safe use (EC 1907/2006) entered into force on 01 June, 2007.

Coherent products are “articles” as defined in REACH Article 3(3) and do not release substances under their normal use. Suppliers of articles must provide recipients with information on Substances of Very High Concern (SVHC) if those are present above a concentration limit of 0.1% on an article level. As Coherent’s duty to communicate information on substances in articles, the delivered product(s), based on Coherent’s knowledge, may contain the listed chemical substance(s) included on the REACH Candidate List at this link: https://edge.coherent.com/assets/pdf/reach_article_33_statement.pdf.

The current Candidate List of SVHCs can be found on the ECHA website <https://echa.europa.eu/home>.

Coherent will post information on SVHCs to our website as the information becomes available and assures its customers that our products are in full compliance the EU REACH requirement. For detailed information on SVHC and Coherent products, please visit <https://www.coherent.com/company/environmental>.

I.5.4 Waste Electrical and Electronic Equipment (WEEE)

The European Waste Electrical and Electronic Equipment (WEEE) Directive (2012/19/EU) is represented by a crossed-out garbage container label. The purpose of this directive is to minimize the disposal of WEEE as unsorted municipal waste and to facilitate its separate collection.



The WEEE Directive applies to this product and any peripherals marked with this symbol. Do not dispose of these products as unsorted municipal waste. Contract the local distributor for procedures for recycling this equipment.

I.5.5 Battery Directive

The batteries used in this product are in compliance with the EU Directive 2006/66/EC ("EU Battery Directive").

Table I-2. Batteries Contained in this Product

Description	Type
3 volt coin cell	Lithium



Dispose of batteries according to local regulations. Do not dispose as normal waste. Consult your local waste authorities for guidance.

I.5.6 Location of Safety Labels

These include warning labels indicating removable or displaceable protective housings, apertures through which laser radiation is emitted, and labels of certification and identification [21 CFR § 1040.10(g), 21 CFR § 1010.2, and 21 CFR § 1010.3]

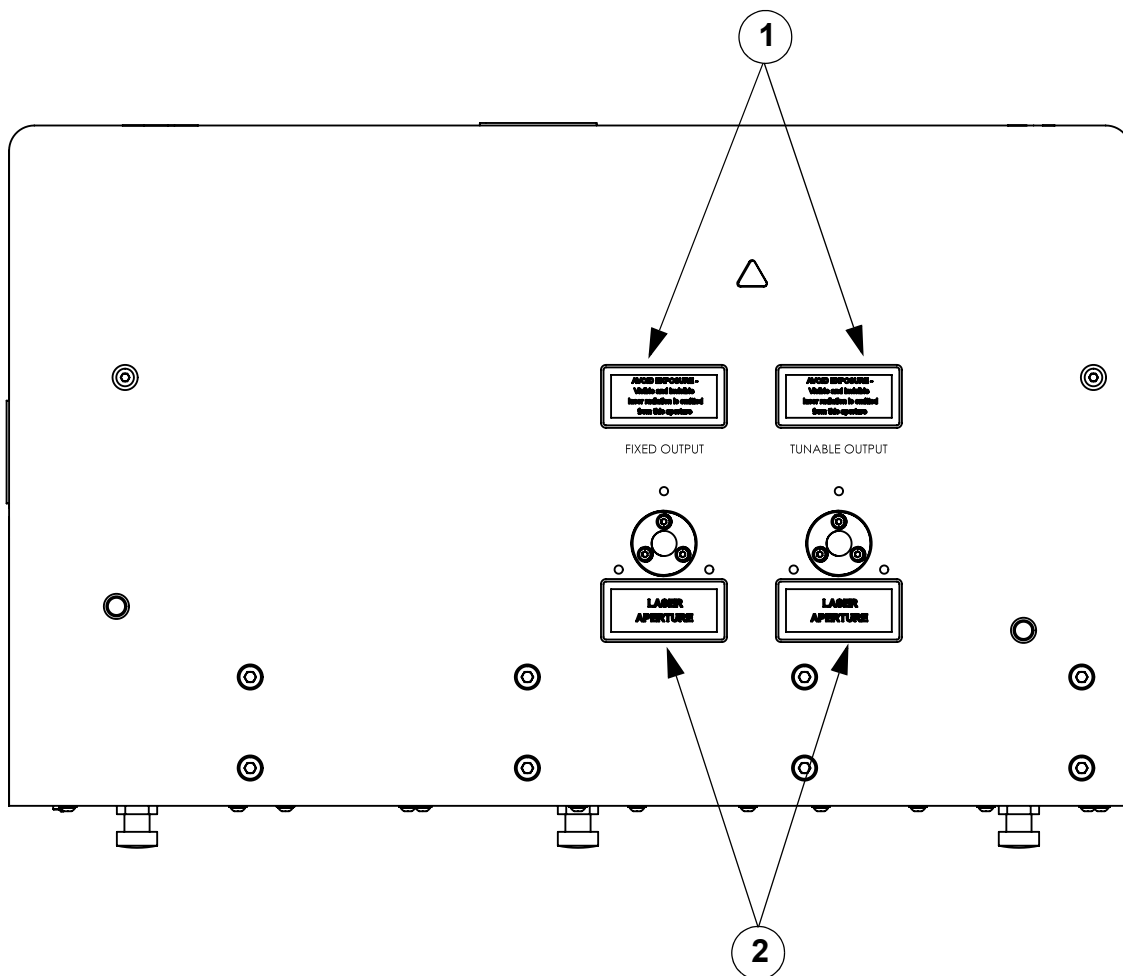

Laser Head - Front View

Figure I-1. Chameleon Discovery NX Laser Safety Features and Labels (Sheet 1 of 6)

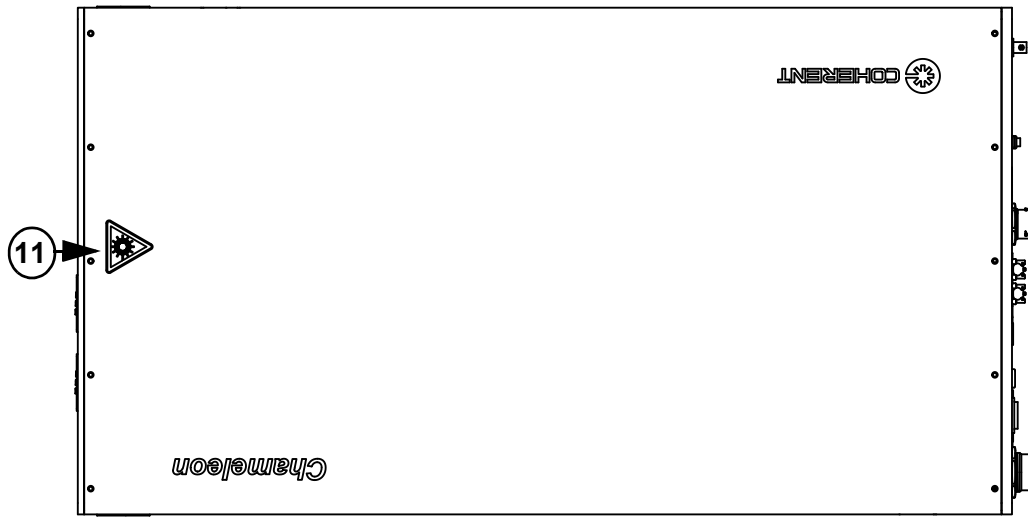

Laser Head - Top View

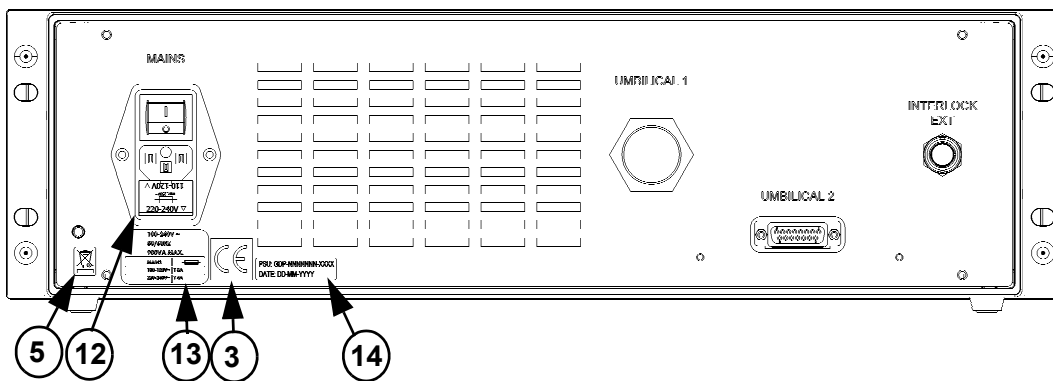

Power Supply - Rear View

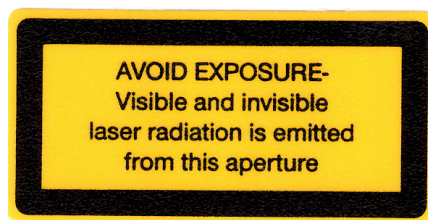

1. Aperture Warning Label

Figure I-1. Chameleon Discovery NX Laser Safety Features and Labels (Sheet 3 of 6)



2. Laser Aperture Indicator Label



3. CE Certification Label



4. UKCA Certification Label



5. Wheelie Bin Disposal Label

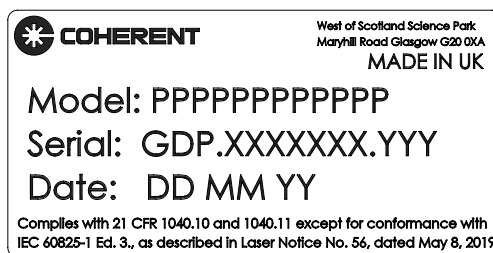

6. Serial Number Label



7. Coolant Label

Figure I-1. Chameleon Discovery NX Laser Safety Features and Labels (Sheet 4 of 6)



8. Maximum Radiation Label

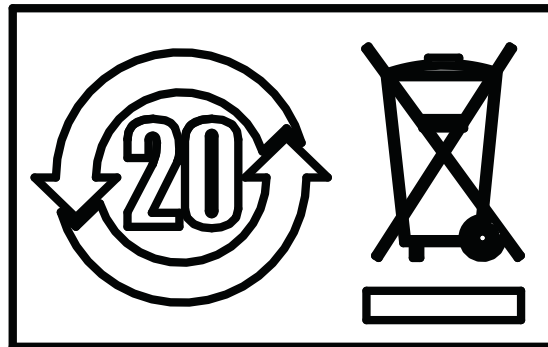

9. China RoHS Label

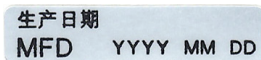

10. Manufacture Date Label

Figure I-1. Chameleon Discovery NX Laser Safety Features and Labels (Sheet 5 of 6)



11. Hazardous Radiation Warning Label



12. Fuse Label

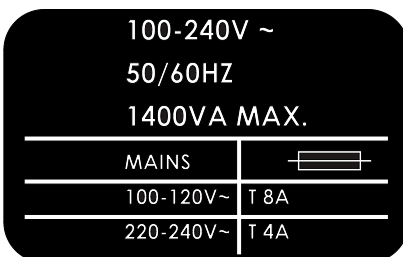

13. Maximum Current Label

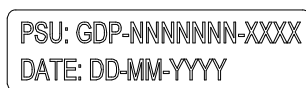

14. Power Supply Serial Label

Figure I-1. Chameleon Discovery NX Laser Safety Features and Labels (Sheet 6 of 6)

I.6 Sources of Additional Information

The following are sources for additional information on laser safety standards and safety equipment and training.

I.6.1 Laser Safety Standard

American National Standard for Safe Use of Lasers

ANSI Z136 Series

American National Standards Institute (ANSI)

www.ansi.org

Performance standards for light-emitting products

21 CFR Title 21 Chapter 1, Subchapter J, Part 1040

U.S. Food and Drug Administration

www.fda.gov

I.6.2 Publications and Guidelines

International Electrotechnical Commission (IEC)

www.iec.ch

Safety of laser products - Part 1: Equipment classification and requirements

BS EN 60825-1

British Standard Institute

www.bsigroup.com

A Guide for Control of Laser Hazards

American Conference of Governmental and Industrial Hygienists (ACGIH)

www.acgih.org

Laser Safety Guide

Laser Institute of America

www.lia.org

This Page Intentionally Left Blank

Appendix II: Parts List

The following parts can be ordered by contacting our Technical Support Hotline at 1-800-367-7890 (1-408-764-4557 outside the U.S.); through E-mail (Customer.Support@Coherent.com); or your local Coherent service representative. When communicating with our Technical Support Department, via telephone or E-mail, the model and Laser Head serial number of your laser system will be required by the Support Engineer responding to your request.

Table II-1. Parts List

Description	Part Number
Major Assemblies	
Rack Mount SMC Chiller	1309119
MRU X1	1309014
Miscellaneous	
Water Hose Kit	1094710
Pure Air Hose Kit	1040787
Shipping Crate, Discovery	1341400
CoolFlow IGE	1234080
Discovery NX Accessory Kit	1413155
Replacement Drying filter cartridge	1310643
MRU X1	
MRU storage accessories and box	1111831

This Page Intentionally Left Blank

Appendix III: Accessories

III.1 Power Meters and Sensors



Shop.coherent is the official e-commerce website for lasers, energy meters and sensors, fiber optics, and accessories. Available for US customers, the e-commerce service offers product search, product-specific filtering, and fast-and-easy checkout with prompt order and shipping confirmations. Visit Shop.coherent.com today!

III.1.1 Coherent's Recommendation

For the most common diagnostics – measuring the output power of the Chameleon Discovery NX – Coherent recommends the a PM10-19C USB sensor (Figure III-1).

The PM10-19C USB sensor is ideal for tight spaces and provides plug and play laser power measurement directly on a PC without the need for additional electronic instrumentation.

Features Include:

- Direct USB 2.0 connection to PC
- Water-cooled
- Spectrally flat from 0.19 μm to 11 μm
- Noise equivalent 0.2 mW to 1 mW
- 19 mm aperture

The PowerMax PC applications software is supplied free with the sensor.

Features Include:

- Trending, tuning, and histogram
- Statistics (mean, minimum, maximum, and standard deviation) and log batch to file
- Operate multiple devices simultaneously and perform synchronized ratiometry (A/B analysis) with trend and log results to file



Figure III-1. PM10-19C USB PN 1168344

Appendix IV: Warranty

Coherent, Inc. warrants the Chameleon Discovery laser systems to the original purchaser (the Buyer) only, that the laser system, that is the subject of this sale, (a) conforms to Coherent's published specifications and (b) is free from defects in materials and workmanship.

Laser systems are warranted to conform to Coherent's published specifications and to be free from defects in materials and workmanship for a period of 13 months or 5000 hours of operation, whichever occurs first. This includes a one month allowance for integration time.

IV.1 Responsibilities of the Buyer

The buyer is responsible for providing the appropriate utilities and a dust-free, temperature regulated operating environment as outlined in the product literature. Damage to the laser system caused by failure of buyer's utilities or failure to maintain an appropriate operating environment, is solely the responsibility of the buyer and is specifically excluded from any warranty, warranty extension, or service agreement.

The Buyer is responsible for prompt notification to Coherent of any claims made under warranty. In no event is Coherent responsible for warranty claims made later than seven (7) days after the expiration of warranty.

IV.2 Limitations of Warranty

The foregoing warranty shall not apply to defects resulting from:

- Components and accessories manufactured by companies, other than Coherent, which have separate warranties,
- Improper or inadequate maintenance by the buyer,
- Buyer-supplied interfacing,
- Operation outside the environmental specifications of the product,
- Unauthorized modification or misuse,
- Improper site preparation and maintenance,

- Opening the pump laser head housing, or
- Opening the sealed UF cavity housing.

Coherent assumes no liability for customer-supplied material. The obligations of Coherent are limited to repairing or replacing, without charge, equipment that proves to be defective during the warranty period. Replacement sub-assemblies may contain reconditioned parts. Repaired or replaced parts are warranted for the duration of the original warranty period only. The warranty on parts purchased after expiration of system warranty is ninety (90) days. Our warranty does not cover damage due to misuse, negligence or accidents, or damage due to installations, repairs or adjustments not specifically authorized by Coherent.

Warranty applies only to the original purchaser at the initial installation point in the country of purchase, unless otherwise specified in the sales contract. Warranty is transferable to another location or to another customer only by special agreement that includes additional inspection or installation at the new site. Coherent disclaims any responsibility to provide product warranty, technical or service support to a customer that acquires products from someone other than Coherent or an authorized representative.

THIS WARRANTY IS EXCLUSIVE IN LIEU OF ALL OTHER WARRANTIES, WHETHER WRITTEN, ORAL OR IMPLIED, AND DOES NOT COVER INCIDENTAL OR CONSEQUENTIAL LOSS. COHERENT SPECIFICALLY DISCLAIMS THE IMPLIED WARRANTIES OF MERCHANTABILITY AND FITNESS FOR A PARTICULAR PURPOSE.

Glossary

°C	Degrees Celsius
°F	Degrees Fahrenheit
μ	Micron(s) = (10 ⁻⁶)
μm	Micrometer(s) = (10 ⁻⁶ meters)
AC	Alternating current
Amp	Amperes
AS	Aqueous slurry
CDRH	Center for Devices and Radiological Health (U.S. Government)
CE	Conformité Européenne, English translation: European Conformity
CFR	Code of Federal Regulation
cm	Centimeter(s)
DC	Direct current
EC	European community
EMC	Electromagnetic compliance
FD	Fine dust
Fu	Fume
FuD	Fume and dust
I	Inhalable
IARC	International Agency for Research on Cancer
IC	Insoluble compounds
I/O	Input/output
IS	Insoluble compounds
kg	Kilogram(s)
LD	Laser diode
LED	Light emitting diode
LVD	Low voltage directive
m	Meter(s)
MAC	Maximal Arbeidsplaats Concentratie
MAK	Maximal Arbeitsplatz-Konzentration
MHz	Megahertz
mm	Millimeter(s)
MSDS	Material Safety Data Sheet
N.A.	Not applicable
N.E.	None established
N.D.	None determined
nm	Nanometer(s)

Chameleon Discovery NX Operator's Manual

OEL/MEL	Occupational exposure standard/maximum exposure limit
TD	Total dust
TEC	Thermo-electric cooler
TWA	Time-weighted average
R	Respirable
SC	Soluble compounds
STEL	Short-term exposure limit
VAC	Volts, alternating current
VDC	Volts, direct current
VME	des Valeurs limits de Moyenne d'Exposition
W	Watt(s)

Index

A

Accessories 115
AOM calibration parameters 58

B

Beam attenuator 101

C

Calibration File Examples 91
Calibration file examples
 Fixed RF Power vs Transmission 93
 Tunable RF Power vs Wavelength vs
 Transmission 91
 Tunable Wavelength vs RF Frequency 92
CDRH compliance
 Beam attenuator 101
 Electromagnetic compatibility 102
 Key control 100
 Laser classification 100
 Laser radiation emission indicators 101
 Manual reset mechanism 101
 Operating controls 101
 Protective housing 100
 Remote interlock connector 100

Chiller

Closed loop 12
Coolant 25
Maintenance 63

Chiller maintenance 63
Chiller diagram 65
Draining chiller 63
Refill chiller 64

Closed loop chiller 12

Command set 45

Communication syntax 41
 ECHO mode 42
 Interface connection
 RS-232 43
 PROMPT mode 43

Compliance

China-Rohs 102
Environmental
 RoHS 102
Safety labels 104

Contacting Coherent Service 61

Control configuration

Direct RF 55
Direct USB 53
Laser control 52
RF driver commands list 54

Controls 29

Controls and indicators

Laser head 29
MRU X1 84
Power supply 31
Crate (contents) 68

D

Dimensions

Chiller 19
MRU X1 85
Standard head 14
System 13
TPC head 16

Drying Filter 88

E

Electrical safety

Guidelines, recommended 98
Precautions, recommended 98

Electromagnetic compatibility 102
MRU X1 79

Environmental Requirements 13

Export control laws compliance 3

External control 41

 Instruction set 44

 Interface 41

 Receiving instruction,Response from Laser 42

 RS-232 pin configuration 44

 RS-232 port configuration 43

 RS-232 port description 43

 USB configuration 44

 USB interface connection 43

 USB port description 44

External interlock 27

F

Fault

Any other fault 61
Contacting Coherent Service 61
External interlock condition 61
Fault condition 60

Features

Laser head 29

Fuse

Ratings 24
Verification 24

H

Handles, lifting (removable) 24, 67

Hazards 95

Housing, protective 100

I

Indicators 29

Chameleon Discovery NX Operator's Manual

Installation	
Chiller coolant	25
External interlock	27
Fuse verification	24
Receiving and inspection	23
System connections	25
Instruction set	44
Command set	45
Query set	47
Interface	41
Command set	45
Communication syntax	41
Query set	47
Interface connection	
USB	43
Interlock	
Connector, remote	100
Interlocks	27
K	
Key control	100
L	
Laser head features	29
Laser safety	9
Guidelines	111
Publications	111
Standards	111
Lifting handles (removable)	24, 67
M	
Maintenance	
Chiller	63
Manual reset mechanism	101
Maximum accessible radiation level	99
Miniature recirculating unit	12
MRU X1	12
Air connections	80
Air ports	85
CE Compatibility	79
Controls	
Front panel	85
Rear panel	85
Controls and indicators	84
Description	73
Dimensions	85
External connections	80
Features	74, 84
Installation	79
Interlocks	86
Mains Power Input	86
Maintenance	87
Drying Filter	88
Inspect/Change	88
Fuse replacement	90
HEPA filter replacement	90
Interlock circuit checkout	87
Operating controls	76
Receiving & inspection	79
Safety	75
Chemical	76
Specifications	73, 75
Troubleshooting	87
O	
Operating controls	101
Operating states	36
ENABLED	36
OFF	36
STANDBY	36
Operation	
Laser head features	29
MRU X1 features	84
Operating states	36
Operator's Manual	
Cited standards	6
Feedback	7
Operator's manual	4
Feedback address	7
Intended audience	5
Laser terminology	6
Measurements, units of	7
Sections, pages and instructions, numbering of	5
Optical safety	96
Guidelines, recommended	97
Precautions, recommended	97
Viewing distance	98
P	
Packing	
Crate	68
Laser head	68
Lifting handles (removable)	67
Packing procedure	67
Parts list	113
Port description	
RS-232	43
USB	44
Power control	
External modulation	56
Software power control	55
Power meters (recommended)	115
Preface	3
PROMPT mode	43
Protective housing	100
Q	
Query set	47
R	
Radiation emission, laser	101
Radiation level, maximum accessible	99
Receiving and inspection	23
Recommended precautions and guidelines	
Electrical	98
Optical	97
Remote interlock connector	100
RS-232	
Configuration	43

- Interface connection 43
- RS-232 pin configuration 44
- RS-232 port configuration 43
- RS-232 port description 43
- S**
- Safety
 - Features and compliance to government requirements 99
 - Features and labels, location of 105
 - Guidelines 111
 - Hazards 95
 - Labels, location of 104
 - Laser 9
 - MRU X1 75
 - Chemical 76
 - Optical 96
 - Publications 111
 - standards, laser 111
 - Safety labels, location of 104
 - Sensors (recommended) 115
 - Signal words 1
 - Specifications 13
 - Symbols 2
 - System
 - Connections 25
 - Description 11
 - Chiller 12
 - Dimensions 13
 - Environmental Requirements 13
 - Laser head 12
 - MRU 12
 - Power supply 12
 - Specifications 13
 - Weight 13
- TPC modulator control
 - AOM calibration parameters 58
 - Calibration for direct USB modulator control 57
 - Configuration set-up 57
 - Control configuration 51
 - Introduction 51
 - Power control 55
 - Specification and description 52
 - TPC overview 51
- Troubleshooting guide 59
 - Any other fault 61
 - Beam pointing varies 60
 - Contacting Coherent Service 61
 - External interlock condition 61
 - Fault condition 60
 - No laser output 59
- Turn-off
 - Complete shutdown 38
 - Daily use 38
- Turn-on
 - Cold start 36
 - Warm start 37
- U**
- USB configuration 44
- USB interface connection 43
- USB port description 44
- V**
- Viewing distance 98
- W**
- Warranty 117
- Waste Electrical and Electronic Equipment (WEEE, 2002) 104
- Weight
 - System 13

This Page Intentionally Left Blank



Chameleon™ Discovery NX Laser Systems Operator's Manual
©Coherent Inc., 11/2022 (RoHS), printed in Scotland
Part No. 1412963 Rev. AF



INNOVATIONS THAT RESONATE



Chameleon™ Discovery NX Laser Systems Operator's Manual
©Coherent Inc., 11/2022 (RoHS), printed in Scotland
Part No. 1412963 Rev. AF