



Laser Beam Delivery by Fiber — A Primer

TABLE OF CONTENTS

Background 2

Fiber Technology 2

Beam Parameter Product 3

The lower beam parameter product, the higher the beam quality 3

Fiber-to-Fiber Coupling 4

Making a Smart Choice in Fiber Delivery 5

Mode Stripper 5

Quartz Block 5

Internal Cooling 5

Pre-aligned Optics 5

Summary 6

Background

Fiber Technology

Fiber delivery uses Total Internal Reflection, which arises when a light beam in a medium with one refractive index impinges at a small angle on a boundary surface of a lower refractive index. When conditions are correct, this reflection is almost perfect and even after a large number of reflections there is little loss of energy.

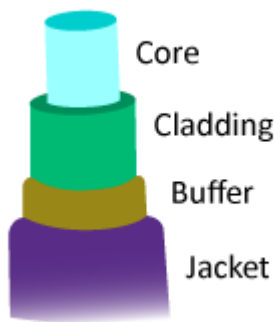

In an optical fiber the part with the higher reflective index is called the “core” and the material, with lower reflective index, surrounding the core, is called the “cladding”. For high power applications, only fibers with a core made of pure fused silica are used. The most common design surrounds the core with a cladding made of doped silica. Outside the cladding, there are at least two more layers to protect the fiber and make it flexible—the “buffer” and the “jacket”.

The basic principle for the high transmission through the fiber is, as described, is total internal reflection. This works only up to a certain angle, and as a result the fiber has a maximum acceptance angle (a_{acc}), it can transmit without losses. The angle depends on the refractive indexes of the core and the cladding.

The larger difference, the larger angle can be transmitted. Any discussion of light transmission or acceptance usually includes the Numerical Aperture ($NA_{fiberacc}$), of the fiber, defined as:

$$NA_{fiberacc} = \sin(a_{acc})$$

The Numerical Aperture of a fiber is given by:

$$NA_{fiberacc} = \sqrt{(n_{core})^2 - (n_{cladding})^2}$$

where n_{core} and $n_{cladding}$ are the refractive index of the core and cladding respectively.

$NA_{fiberacc}$ represents the maximum angle that can be transmitted by the fiber without loss.

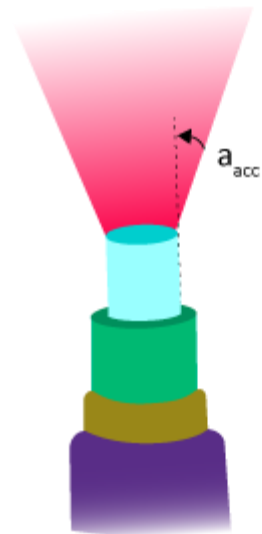

Beam Parameter Product

The Beam Parameter Product (BPP) quantifies the quality of a laser beam and how well it can be focused. It is the product of a laser beam's far-field divergence angle (half-angle) and the radius of the beam at its narrowest point (the beam waist).

For minimal degradation of the BPP in transmission through the fiber, the coupling optics have to be optimized. A typical way to describe the BPP is to measure the beam waist radius where 86% ($1/e^2$) of the radiation falls, and the divergence angle (half angle) measured with the same 86% values. The 86% BPP values are not the optimum for use in design of fiber optics, as then 14% of the power is lost in the coupling. We calculate these values based on the BPP measured at the 98% values, with respect to both beam waist and angle.

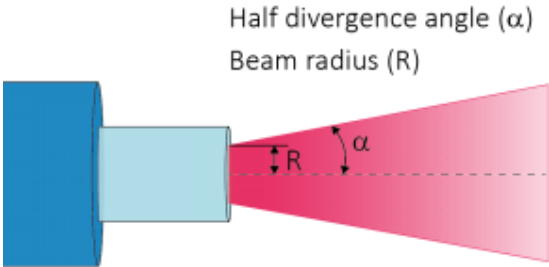

The BPP value of the laser beam delivered from a fiber optic cable is given as the product of fiber core radius and output divergence angle (half angle). Smaller fiber core radius and/or smaller output divergence angle give a better beam quality (lower BPP-value).

The lower beam parameter product, the higher the beam quality

The relation between the two BPP values depends on the beam profile. As a rule of thumb we normally use a factor 1.5 as the relation between the 86% ($1/e^2$) and 98% BPP value.

$$BPP_{98\%} / BPP_{86\%} = 1.5$$

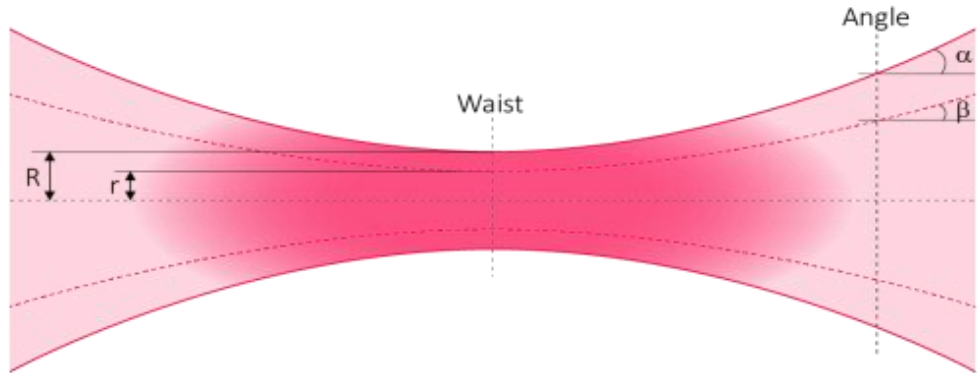

$$98\% \text{ BPP} = R \times \alpha \text{ (mm x mrad)}$$

$$86\% \text{ BPP} = r \times \beta \text{ (mm x mrad)}$$

A different and very common beam quality measurement is the M^2 value. The M^2 value is a normalization of the BPP value. The normalization is made against a diffraction limited beam at a specific wavelength.

$$M^2 = BPP / BPP_0$$

$$BPP_0 = \lambda / \pi$$

M^2 is dimensionless.

BPP_0 = diffraction limited beam

$$M^2 \geq 1$$

Fiber-to-Fiber Coupling

The basic principle in fiber-to-fiber coupling is simply to reimage the fiber end surface from the emitting fiber onto the receiving process fiber. Using an optimized system, losses will be low for both power and beam quality (BPP).

In the nominal situation with the beam collimated between the two optics, the image of the feeding fiber is magnified with a factor M onto the process fiber.

$$M = f_{\text{foc}} / f_{\text{coll}}$$

The magnification factor M , not only magnifies the image onto the process fiber, but also reduces the incoming angle by the same amount. Larger magnification leads to a smaller coupling angle with a decrease of [BPP](#) losses as a result. When the magnification becomes too large and the fiber core become overfilled, power losses increase significantly.

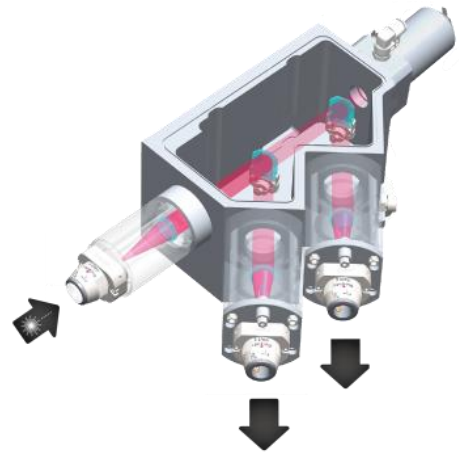

Coupling laser light from the feeding fiber to any of the process fibers in a Fiber to Fiber Optic Switch (FFS).

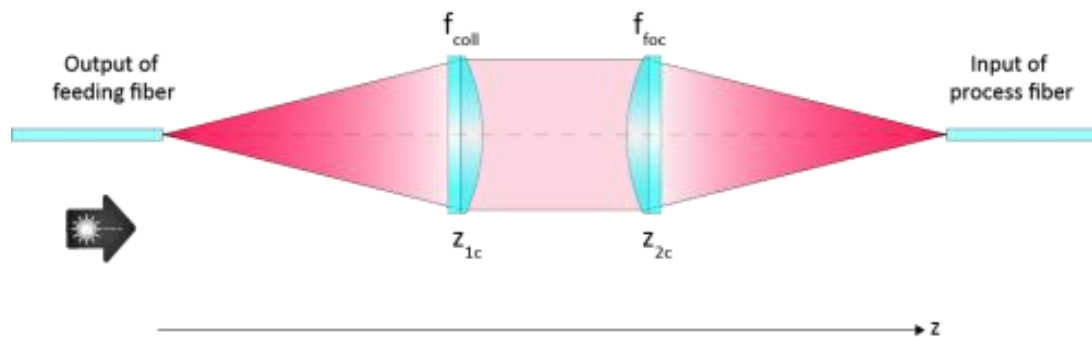

Making a Smart Choice in Fiber Delivery

When using an optical fiber for high power transmission, it is critical to address power loss due to misalignment, back reflections or damaged optics in the beam path. Generally the main loss points are the entrance and exit surfaces, and the area where the buffer and jacket enter the fiber.

Mode Stripper

In all Coherent (Optoskand) fiber optic cables, a mode stripper solution is used to clean the cladding from unwanted back-reflected radiation before the buffer/jacket enters the fiber. It makes the radiation leak out of the cladding where it is easier to dissipate and cool.

Quartz Block

All Coherent (Optoskand) fiber optic cables are equipped with a quartz block at the fiber end. This results in three main advantages:

- A larger entrance surface results in a lower power density on the fiber end surface.
- Mechanical mounting of the fiber is easier and results in a more precise position of the fiber.
- Enables the use of AR coating, thereby decreasing transmission losses to the order of 1-2%.

Internal Cooling

In some of Coherent's (Optoskand) fibers (QBH, QD), the volume behind the quartz block is filled with circulating cooling water. This means that the radiation removed from the cladding by the mode stripper is directly absorbed in water, rather than being absorbed in a metal part that is water-cooled. This technology very efficient and power losses in the range of kilowatts can be dissipated.

Pre-aligned Optics

The effective focal length of a lens includes some specified tolerances. To guarantee plug-and-play performance, these tolerances need to be compensated for. The process optics modules are pre-aligned during assembly. The alignment process is made with a reference fiber and calibrated measurement equipment. The lens is moved to the position to collimate the beam then fixed in place.

The *Effective Focal Length (EFL)* is related to the imaging properties of the lens and is what we normally call the focal length of the lens.

The *Design Focal Length (DFL)* of the focusing unit is related to the working distance of the focusing unit. The DFL is chosen to be close to the EFL and defines the distance from our mechanical interface to the focal spot position of a parallel incoming beam. The optics are pre-aligned to adjust for variations due to tolerance in EFL and/or Back Focal Length.

The *Back Focal Length (BFL)* is the distance from the exit side of a lens on the optical axis to the focal point, assuming a parallel incoming beam. This distance is not used in the description of the focusing optics, but defines the position of the lens seat within the holder.

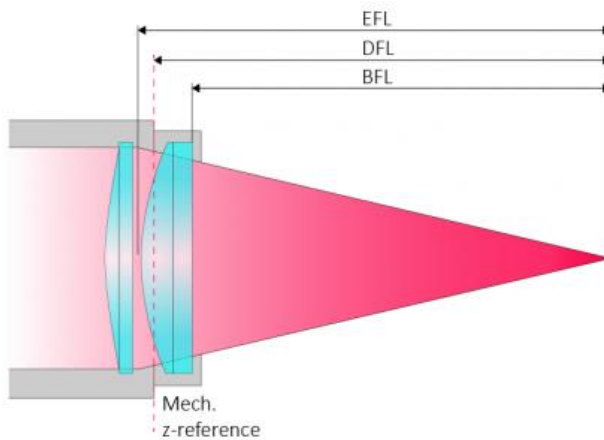

Pre-aligned optics make it easy to get into focus.

Summary

Optimized high-power laser beam delivery involves careful consideration for loss elements such as misalignment or back reflections, maximization of BPP and precise factory alignment to ensure plug-and-play simplicity and long service life.