

Non-Amplified High Speed Fiber Photodetectors



Thank you for purchasing your High Speed Fiber Photodetector from Coherent. This user guide will help answer any questions you may have regarding the safe use and optimal operation of your Photodetector.

TABLE OF CONTENTS

I. High Speed Fiber Photodetector Overview 1

II. Operation of your Coherent High Speed Fiber Photodetector 2

III. Troubleshooting 2

IV. Schematics: High Speed Fiber Photodetectors 3

V. Warranty Statement and Repair 3

VI. Glossary of Terms 4

I. High Speed Fiber Photodetector Overview

Coherent High Speed Fiber Photodetectors contain PIN photodiodes that utilize the photovoltaic effect to convert optical power into an electrical current. Figure 1 below identifies the main elements of your Fiber Photodetector.

Figure 1: Coherent High Speed Fiber Photodetector

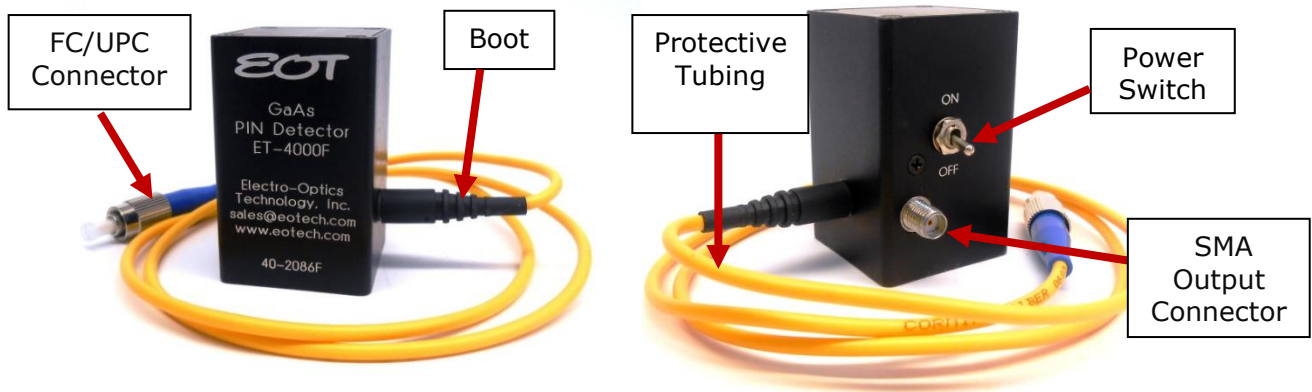

When terminated into 50 Ω into an oscilloscope, the pulsewidth of a laser can be measured. When terminated into a spectrum analyzer, the frequency response of a laser can be measured.

II. Operation of your Coherent High Speed Fiber Photodetector

- A. Caution: Eye safety precautions must be followed when utilizing any equipment used in the vicinity of laser beams. Laser beams may reflect from the surface of the detector or the optical mount and caution must be exercised.
- B. Clean the end of the fiber ferrule and connect to the laser.
- C. Adjust the voltage of the oscilloscope to 50 mV/division before connecting the detector.
- D. Connect the detector to the oscilloscope using a coaxial cable designed for up to 26 GHz operation.
- E. Use the 50 Ω termination input of the oscilloscope.
- F. After being certain that the damage threshold of the detector is not exceeded, turn on the laser.
- G. There is an internal 50 Ω resistor at the output of the photodiode. This will cause the output current to your test equipment to be half that of the photodiode output. For example, the output to your equipment will be 450 μ A for a 1 mW optical input at 0.9 A/W. Some losses will also exist in the fiber cable and connectors.

III. Troubleshooting

A. No signal is seen the first time the detector is used:

- 1. Is the power switch on?
- 2. Be certain that the signal is not high off scale on the oscilloscope.
- 3. Is the wavelength of the laser within the spectral range of the detector?
- 4. Has a 50 Ω termination input been used?
- 5. Make sure the fiber radius is greater than 1 inch. Inspect fiber for damage.
- 6. Is there enough light (see sensitivity spec on the data sheet) incident on the detector to generate a signal?

B. A signal has been previously obtained, but not currently:

- 1. Try steps listed under A.
- 2. Test the power supply:
 - a. Units with internal batteries will typically operate for several years, but operation with CW or high rep rate lasers can drain the batteries much faster. **If a load is present at the output, current will be drawn from the batteries, turn off the power switch when not in use.** Remove top cover to replace the 3 V lithium cells with Duracell Model DL2430, positive side down.
 - b. Units with an external power supply should at least receive the voltage that is printed on the plug.

C. Increasing the power incident on the detector does not result in a higher voltage signal on the oscilloscope:

- 1. The detector is probably saturated. You should lower the power incident on the detector to a level below the saturation point.

IV. Schematics: High Speed Fiber Photodetectors

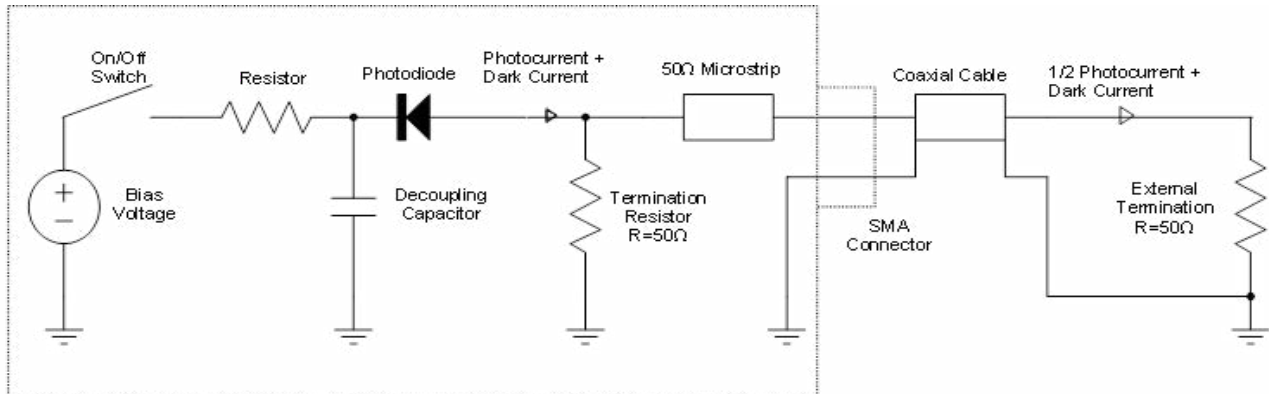

V. Photodetector Warranty and Service

Limited Warranty: Coherent, Inc. warrants to the original purchaser that its Photodetectors are free from defects in materials and workmanship and comply with published specifications, active at the time of purchase, for a period of twelve (12) months. Coherent, Inc., will at its option, repair or replace any product or component found to be defective during the warranty period. This warranty applies only to the original purchaser and is not transferrable.

Return Instructions for Warranty or Service Repair

Obtaining Warranty Service: For warranty service, please contact your closest Coherent service center (see below) to obtain a Return Material Authorization (RMA) number.

Instructions for Returning your Coherent Photodetector: To prepare your Photodetector for return to Coherent, attach a tag to the unit that includes the name and address of the owner, the contact individual, the serial number, and the RMA number you received from Customer Service.

Email address for warranty and repair are:

China: service.china@coherent.com

Europe: service.dieburg@coherent.com

Japan: svc.jpn@coherent.com

Korea: service.korea@coherent.com

North America: customer.support@coherent.com

PIR (Southeast Asia): service.asean@coherent.com

Taiwan: twn.customer.support@coherent.com

VI. Glossary of Terms

Bandwidth:

The range of frequencies from 0 Hz (DC) to the frequency at which the amplitude decreases by 3 dB. Bandwidth and rise time can be approximately related by the equation:

$$\text{Bandwidth} \approx 0.35/\text{rise time for a Gaussian pulse input.}$$

Bias Voltage:

The photodiode's junction capacitance can be modified by applying a reverse voltage. The bias voltage reduces the junction capacitance, which causes the photodiode to have a faster response.

Conversion Gain:

The relative level of the optical input power that is amplified and converted into a voltage output.

Dark Current:

When a termination is present, a dark current (nA range) will flow if the photodiode is biased. Disconnecting the coaxial cable will prevent this current from flowing.

Decoupling Capacitor:

Maintains bias voltage when fast pulses cause the battery voltage to reduce (this would slow the response time of the photodiode); the capacitor allows the battery to recover to its initial voltage. It also acts as a low-pass filter for external power supplies.

Noise Equivalent Power (NEP):

A function of responsivity and dark current and is the minimum optical power needed for an output signal to noise ratio of 1. Dark current is the current that flows through a reverse biased photodiode even when light is not present, and is typically on the order of nA. Shot noise (I_{shot}) is a source of noise generated in part by dark current; in the case of reversed biased diodes it is the dominant contributor.

Photodiode:

Converts photons into a photocurrent.

Resistor:

Part of the low-pass filter at the photodiode cathode.

Responsivity:

In amps per watt (A/W), responsivity is the current output of the photodiode for a given input power, and is determined by the diode structure. Responsivity varies with wavelength and diode material.

Rise Time/Fall Time:

Rise Time is the time taken by a signal to change from a specified low value to a specified high value. Fall Time is the time taken for the amplitude of a pulse to decrease from a specified value to another specified value. A larger junction capacitance will slow the detector's response time.

SMA Connector:

Used to connect the customer's coaxial cable for high frequencies.

Termination Resistor (50 Ω):

Reduces signal reflections and balances the 50 Ω microstrip/coaxial cable lines. As a result, half the photodiode current is lost to the internal resistor.

[CLICK HERE TO SPEAK WITH OUR EXPERTS](#)

