



High Repetition-Rate EnergyMax Sensors

Energy Range 100 nJ to 1 J

These sensors incorporate a diffuse metallic coating that enables measurements at high and low repetition rates across a wide range of energies, and wavelengths from 190 nm to 2.1 μm . These sensors are not compatible with FieldMaxII meters because the response time is too fast. They are best suited for the LabMax-TOP or LabMax-Pro SSIM meters.

FEATURES

- Unique diffuse metallic coating delivers increased damage threshold, allows high repetition rate operation and reduces specular reflectance
- Operate over the entire 190 nm to 2.1 μm range
- Enable pulse energy measurements from 100 nJ to 1J with high signal-to-noise characteristics
- Measure up to 10 kHz repetition rate

APPLICATIONS

- Medical
- Scientific
- Industrial
- Laser Rep Rates up to 10 kHz



High Repetition-Rate EnergyMax Sensors Datasheet

SPECIFICATIONS	J-50MT-10KHZ-1571	J-50MT-10KHZ
Energy Range	90 μ J to 100 mJ	500 μ J to 1 J ¹
Noise Equivalent Energy (μ J)	<9	<16
Wavelength Range (μ m)	0.19 to 2.1	
Active Area Diameter (mm)	50	
Max. Average Power ² (W)	20	
Max. Pulse Width (μ s)	1.7	
Max. Rep. Rate (pps)	10,000	
Max. Energy Density (mJ/cm ²)	500 (at 1064 nm, 10 ns)	
Detector Coating	Diffuse Metallic	
Diffuser	No	
Calibration Wavelength (nm)	1064	
Calibration Uncertainty (%) (k=2)	\pm 2	
Energy Linearity (%)	\pm 3	
Cable Length ³ (m)	2.5	
Cable Type	J DB-25	
Part Number	1185709	1110574 ⁴

SPECIFICATIONS	J-25MT-10KHZ	J-10MT-10KHZ
Energy Range	50 μ J to 100 mJ	100 nJ to 200 μ J
Noise Equivalent Energy	<2 μ J	<10 nJ
Wavelength Range (μ m)	0.19 to 2.1	
Active Area Diameter (mm)	25	10
Max. Average Power ² (W)	10	1
Max. Pulse Width (μ s)	1.7	
Max. Rep. Rate (pps)	10,000	
Max. Energy Density (mJ/cm ²)	500 (at 1064 nm, 10 ns)	50 (at 1064 nm, 10 ns)
Detector Coating	Diffuse Metallic	
Diffuser	No	
Calibration Wavelength (nm)	1064	
Calibration Uncertainty (%) (k=2)	\pm 2	
Energy Linearity (%)	\pm 3	
Cable Length ³ (m)	2.5	
Cable Type	J DB-25	
Part Number	1110747 ⁴	1110856 ⁴

- ¹ Optional energy range 50 μ J to 100 mJ available.
² Extend average power range with optional heat sink.
³ Cable lengths up to 10m possible. Contact factory.
⁴ 1 Day Ship program: eligible for next business day shipment.

MECHANICAL SPECIFICATIONS

J-50MT-10KHZ

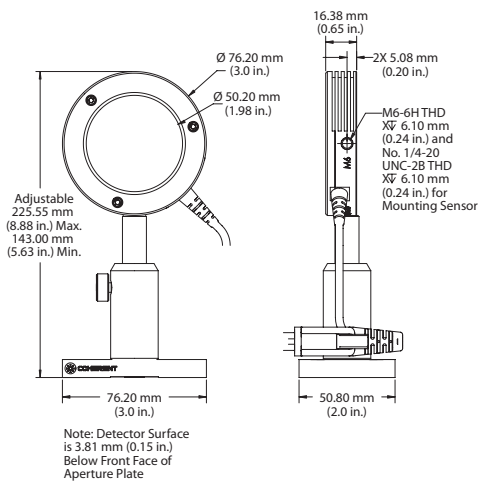

J-25MT-10KHZ

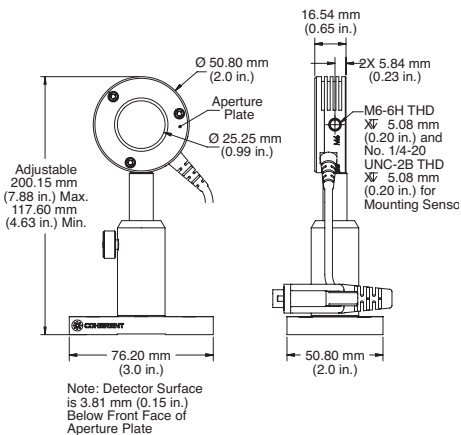

J-10MT-10KHZ

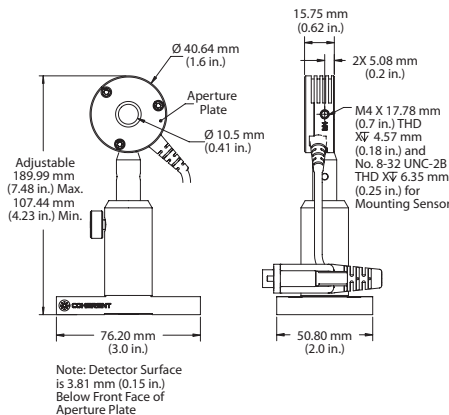

Coherent, Inc.,
 5100 Patrick Henry Drive Santa Clara, CA 95054
 p. (800) 527-3786 | (408) 764-4983
 f. (408) 764-4646

tech.sales@coherent.com www.coherent.com

Coherent follows a policy of continuous product improvement. Specifications are subject to change without notice. Coherent's scientific and industrial lasers are certified to comply with the Federal Regulations (21 CFR Subchapter J) as administered by the Center for Devices and Radiological Health on all systems ordered for shipment after August 2, 1976.

Coherent offers a limited warranty for all EnergyMax Sensors. For full details of this warranty coverage, please refer to the Service section at www.coherent.com or contact your local Sales or Service Representative.
 MC-019-21-0M0621 Copyright ©2021 Coherent, Inc.