



META 5C

Flatbed CO₂ Laser Cutting System

Flexible, High-Speed Precision

The META 5C is a versatile solution for precision cutting of a broad mix of materials, ranging from thin metals to non-metal materials like plastics and organics, including leather, textiles, and wood (up to 31.75 mm). The simple user interface and CAM software simplify work setup, increase productivity, and provide greater file development flexibility. Rapid switching between jobs without the downtime of lengthy setup supports economical production of lot sizes from single units to volumes of over 1000 pieces.

This versatile CO₂ laser cutting system finds its way into a broad variety of environments and markets including defense, point of sale displays, electronics, white goods, medical devices, consumer displays, job shops, and R&D labs (commercial, academic, and governmental).



FEATURES & BENEFITS

- Sealed-slab CO₂ laser for high power, low operating cost, and long life
- Built-in routines for motion management to facilitate process setup and operation
- Gull wing doors for complete access to the large work area from the front or rear of the machine
- Optional vision system for precise fiducial alignment of pre-patterned substrates
- Optional pallet automation for substantially higher throughput (load/unload while processing the next sheet)
- All new graphical user interface for easy job setup and job queue management

APPLICATIONS

- Cutting
- Marking
- Engraving

SPECIFICATIONS ¹	META 5C-2	META 5C-4
Laser Power/Peak Power (W)	250/750	450/1800
Laser Wavelength (µm)	9.4	10.6
Dimensions (L x W x H)	1630 x 1990 x 1320 mm (64.2 x 78.4 x 52.0 in.)	
Weight	1136 kg (2250 lbs.)	
Cutting Height	1020 mm (40.0 in.)	
Working Range	x = 1220 mm (48.0 in.) y = 1220 mm (48.0 in.) z = 300 mm (12.0 in.)	
Maximum Speed	50,800 mm (2000 in.)/min. cutting 91,500 mm (3600 in.)/min. rapid positioning 50,800 mm (2000 in.)/min. raster engraving	
Positioning	Linear encoders with 2 micron resolution in closed loop with brushless servo motors	
Accuracy ²	25 µm (0.001 in.) positioning accuracy 5 µm (0.0002 in.) repeatability	
Contouring	Full look-ahead contouring capability	
Materials	Acrylic, Aluminum, Ceramic, MDF, Mild Steel, Stainless Steel, Wood	
Software Interface Coreo Command HMI Software program: Optional Coreo Design and Build CAD/CAM software with a True Shape Nesting option	Windows 10 support G-code support AI, BDG, BMP, DXF, DWG, Gerber, JPG, LMC, TIF, XML file import Full geometry editing in the CAM package, partial in the HMI Editable database of laser parameters including universal parameter change saves and new parameter addition Job estimator software Job management software	
Cutting Pallets	Removable pallet system with front and rear pass-through Honeycomb or points work support	
Pallet Area	1.2 x 1.2 m (48 x 48 in.)	
Laser Power Control	Digital laser power control Power proportional to velocity	
Focusing	Auto-focus, capacitive height control for metal substrates	
Exhaust/Vacuum Bed	Vacuum material hold-down plenum External high pressure exhaust blower required	
Cooling	External chiller required (offered as an option)	
PC/File Server	Windows/Ethernet	
Power (VAC)	30A 40A 208 to 240, 47 to 63 Hz, three-phase, can be tapped for 400V	
Safety	Safety interlocks on all covers and enclosures Class I system (Complies with 21 CFR Chapter 1, Subchapter J)	
User Controls	Touch Screen control panel Jog, Bed height controls Home, Park, Load buttons Exhaust, gas assist controls Editing of laser settings Networked HMI workstation Auto restart Optional bar code reader	
Environmental	Ambient temperature range of 10 to 38°C (50 to 100°F)	
Laser Tool Capabilities	Raster engraving, marking, and cutting	
Regulatory Compliance	CE marked	

¹ These specifications are applicable as of May 2015 and are subject to change without notice.

² Accuracy quoted is under controlled conditions and measured across a 300 mm (12") distance. Accuracy may vary depending on substrate variability, process settings and conditions in the customer facility.

MECHANICAL SPECIFICATIONS

META 5C

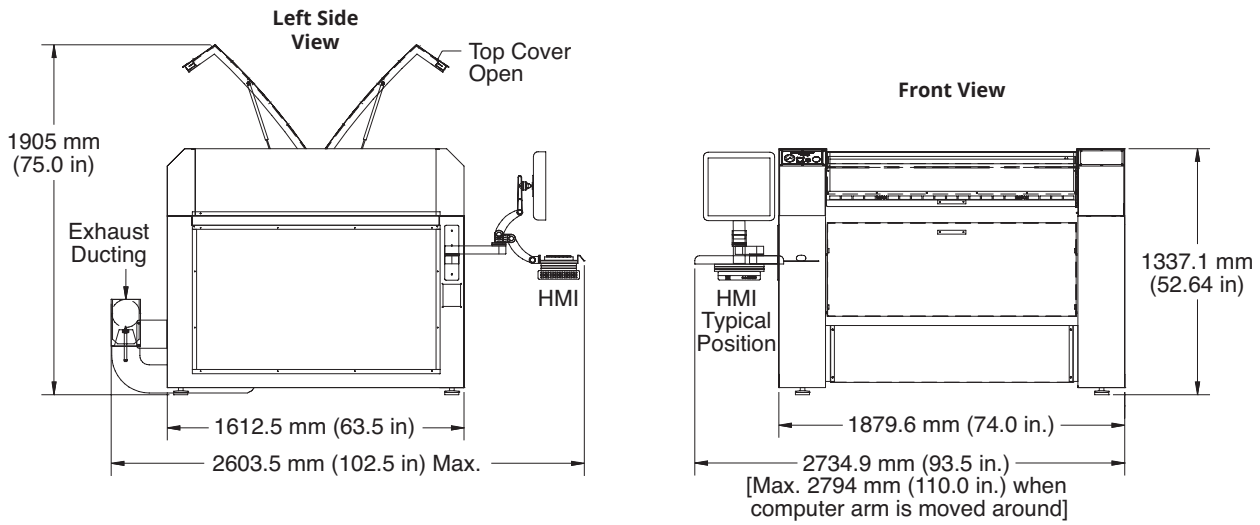

Coherent, Inc.,
 5100 Patrick Henry Drive Santa Clara, CA 95054
 p. (800) 527-3786 | (408) 764-4983
 f. (408) 764-4646

tech.sales@coherent.com www.coherent.com

Coherent follows a policy of continuous product improvement. Specifications are subject to change without notice. Coherent's scientific and industrial lasers are certified to comply with the Federal Regulations (21 CFR Subchapter J) as administered by the Center for Devices and Radiological Health on all systems ordered for shipment after August 2, 1976.

Coherent offers a limited warranty for all META Laser Machining Centers. For full details of this warranty coverage, please refer to the Service section at www.coherent.com or contact your local Sales or Service Representative. Printed in the U.S.A. MC-005-15-0M1020Rev.C. Copyright ©2020 Coherent, Inc.