

DIAMOND Cx-10LDE+

Sealed CO₂ Laser with Integrated AOM

As part of the C/Cx-series from Coherent, the Cx-10LDE+ CO₂ laser provides superior pulse control and power stability with its fully integrated acoustic optical modulator (AOM). Based on the Cx-10 laser platform, the Cx-10LDE+ is a production-ready, easy-to-integrate laser system enabling the highest quality laser processing with low maintenance and operating cost. The extreme pulse control provided by the AOM makes this laser especially useful for high precision applications such as film cutting in flat panel display manufacturing, high resolution marking, and other functions requiring a true "on/off" pulse.

FEATURES & BENEFITS

- Fully integrated AOM providing excellent pulse control.
- Superior power stability improves processing consistency and repeatability
- Modular RF board and AOM design allows for easy serviceability
- Small footprint for easy integration
- Pulse rise/fall times of <math><1 \mu\text{s}</math> minimize heat affected zones and provide high precision process control

APPLICATIONS

- High volume marking, cutting, and engraving
- Film cutting and processing
- Process wide range of materials from acrylics, cardboard, ceramics, glass, polymer films, leather, paper, textiles, wood, and PCBs



SPECIFICATIONS	Cx-10LDE+ 10.6 μm	Cx-10LDE+ 10.2 μm	Cx-10LDE+ 9.6 μm	Cx-10LDE+ 9.3 μm
Wavelength (μm)	10.6 \pm 0.03	10.2 \pm 0.05	9.6 \pm 0.05	9.3 \pm 0.05
Laser Power at 50% Duty Cycle ^{1,2} (W)	\geq 45	\geq 40	\geq 30	\geq 30
Typical Peak Output Power (W)	>120	>120	\geq 85	\geq 85
Power Stability ^{1,2} (%)	\pm 3 (\pm 0.1 $^{\circ}\text{C}$ coolant stability after 10 minute warm-up)			
Pulse Rise and Fall Time (μsec)	\leq 1 (10% to 90%)			
Beam Quality (M^2)	\leq 1.2			
Beam Output Diameter (mm) (nominal)	5.5 \pm 1.5			
Beam Waist Diameter (mm) (nominal)	3.4 \pm 0.3	3.4 \pm 0.3	2.7 \pm 0.3	2.7 \pm 0.3
Beam Divergence (mrad) (full angle)	\leq 5.5			
Beam Ellipticity ³	\geq 0.83, \leq 1.2			
Pointing Stability ⁴ (% divergence/actual μrad)	\leq 750 μrad			
Polarization ⁵	Vertical \geq 100:1			
Operating Frequency and Duty Cycle ⁶	0 to 200 kHz, 1% to 100% DC			
CONFIGURATION AND FACILITY REQUIREMENTS				
Weight (kg)	23.0 kg (50.5 lbs)			
Dimensions (L x W x H)	670.8 x 176.5 x 186.9 mm (26.41 x 6.95 x 7.36 in.)			
Input Power	48 VDC, 45A			
Heat Dissipation (W)	\leq 2300			
Maximum Case Temperature	$<$ 60 $^{\circ}\text{C}$ (140 $^{\circ}\text{F}$)			
Clean Dry Air Purge ⁷	$>$ 5 slph (0.177 scfh)			
Operating Environment				
Temperature	5 $^{\circ}\text{C}$ to 45 $^{\circ}\text{C}$ (41 to 113 $^{\circ}\text{F}$)			
Altitude	\leq 2000 m (6500 ft)			
Humidity	Non-condensing \leq 95%			
Shipping/Storage Environment	-10 $^{\circ}\text{C}$ to +60 $^{\circ}\text{C}$ (14 to 140 $^{\circ}\text{F}$), Non-condensing			
Coolant	Distilled water with 25% to 35% Dow Frost*			
Coolant Flow Rate	\geq 5.7 l/min. (1.5 gpm)			
Maximum Coolant Pressure	700 kPa (101 psig)			
Max. Pressure Differential (at 1.5 gpm)	$<$ 400 kPa (58 psig)			
Coolant Temperature	20 $^{\circ}\text{C}$ \pm 1 $^{\circ}\text{C}$			

¹ All measurements, such as power made at 20 $^{\circ}\text{C}$ \pm 0.5 $^{\circ}\text{C}$ coolant temperature, AOM PRF 25 kHz.

² Power Stability based on $\pm(P_{\text{max}}-P_{\text{min}})/(2*P_{\text{max}})$ average power measurement under the following conditions: AOM PRF 25kHz; AOM duty cycle 50%; Cx-10 laser duty cycle 100%; and after 10 minute warm up period with 10 minute measurement duration.

³ Ratio based on far field divergence measurement, defined as the ratio of vertical to horizontal divergence.

⁴ Measured as the steady state angular beam centroid change between a 5% AOM duty cycle and a 95% AOM duty cycle. Steady state is defined as the angular beam centroid location after 1 minute of operation at the specific AOM duty cycle and with a 100% Cx-10 duty cycle after a 10 minute Cx-10 warm up period.

⁵ Refer to Mechanical Specifications for beam polarization orientation.

⁶ Operation at pulse repetition frequencies above 200 kHz may result in substantial side lobe power and reduced beam quality.

⁷ Dry Nitrogen is also acceptable as a purge gas.

* Dow Frost is a trademark of the Dow Chemical Company.

MECHANICAL SPECIFICATIONS

DIAMOND Cx-10LDE+

Top View

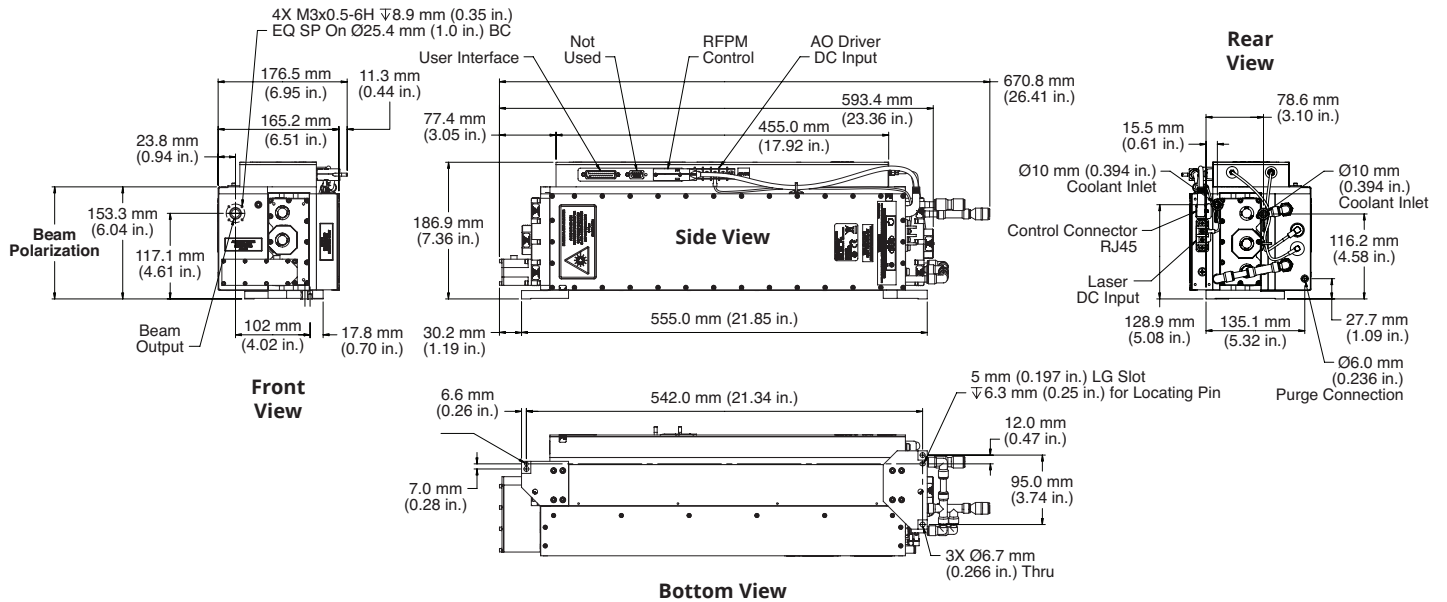
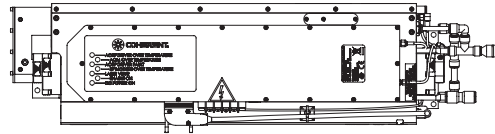

Coherent, Inc.,
 5100 Patrick Henry Drive Santa Clara, CA 95054
 p. (800) 527-3786 | (408) 764-4983
 f. (408) 764-4646

tech.sales@Coherent.com www.coherent.com

All specifications subject to change without notice. Coherent, Inc. warrants to the original purchaser for a period of two years from the date of delivery that the DIAMOND Cx-10LDE+ product is free from defects in material and workmanship. The warranty does not apply to any unit damaged by accident, abuse or operation in a manner inconsistent with the procedures and specifications outlined in the manual supplied with the laser.

The DIAMOND Cx-10LDE+ CO₂ laser is a component that does not include all safety features as required by the FDA and the Center for Devices and Radiological Health (CDRH). It is sold solely to qualified manufacturers who in their end product will supply all interlocks and indicators, and will comply fully with CDRH regulations and/or local regulatory agencies. MC-013-17-0M1219Rev.C Copyright ©2019 Coherent, Inc.