

The Digital Display Revolution: Built on Excimer Laser Annealing

Excimer laser annealing (ELA) of amorphous silicon (a-Si) to low temperature poly-silicon (LTPS) is a pivotal technology for increasing the pixel density in high-end thin film transistor displays. Excimer laser line beam systems foster large panel annealing of AMLCD and AMOLED backplanes for smartphones and OLED-TVs as well as polymer based flexible display manufacturing

Rising Demand for Polysilicon (LTPS) Backplanes

With mobile phone market growth occurring as a result of the transition to smart phones, demand has increased for higher specifications, including display size, resolution, and battery life. The fastest-growing display technology is AMOLED, which is forecast to reach 128 million units (191% Y/Y) in 2011 and 212 million (66% Y/Y) in 2012 (see Fig.1). AMOLED revenues for mobile phone displays will reach \$4.0 billion in 2011 and \$6.4 billion in 2012.

LTPS (low-temperature polysilicon) is the enabling display manufacturing technology, and currently is the only method of mass producing AMOLEDs. Amorphous Si (a-Si) TFT LCD continued to lead with 61.5% of mobile phone displays in 2010. However, LTPS TFT LCD is very competitive in smart phones, which requires higher resolution and pixels per inch.

Mobile Phone Display Revenue Forecast in Millions
(Source: Display Search)

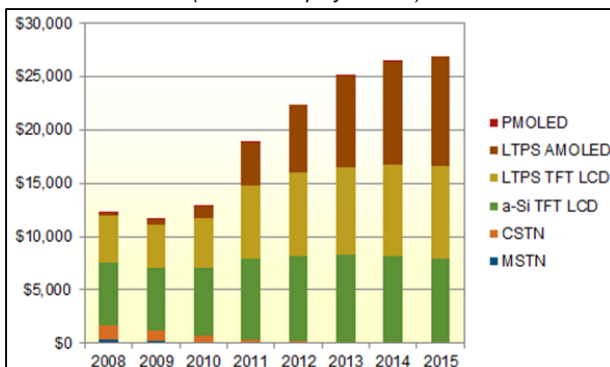

Figure 1

LTPS TFT LCD is shifting to bigger sizes for smart phones. LTPS, capacity expansions are ongoing.

LTPS FPD Manufacturing Equipment Market Revenues
(Source: Display Search)

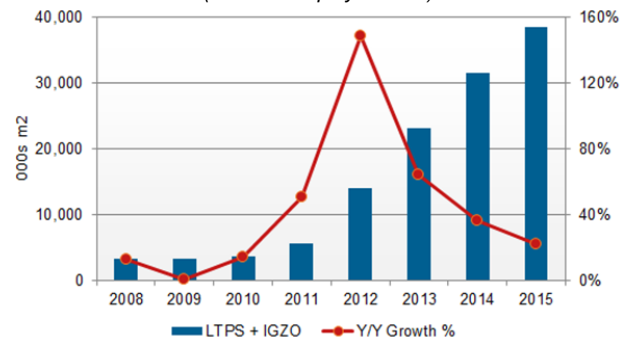

Figure 2

Not only is the number of new LTPS-related investments extraordinary, but leading panel makers are, for the first time ever, scaling LTPS technology to Gen 5.5 and larger substrates (see table 1). Looking ahead, LTPS capacity expansions and equipment spending will remain high.

LCD Glass Input for Smartphone and Tablet PC by Generation
(Million m² per Month)

Fab	Q1'11	Q2'11	Q3'11	Q4'11	Q1'12
Gen3.5	10.8%	13.0%	8.1%	5.9%	0.1%
Gen4	1.4%	0.4%	0.1%	0%	0%
Gen5	83.9%	83.9%	74.1%	57.1%	49.4%
Gen6	3.2%	3.2%	17.7%	16.8%	10.1%
Gen8	0.7%	0.7%	0%	20.3%	40.5%

Table 1

Already beckoning is the next killer application for LTPS backplanes. The market for large-area OLED-TV displays is projected to come into existence in 2013 (see Fig.3). To this end, upscaling of LTPS technology to Gen 8 substrates covering up to six 55 inch OLED TV displays per panel is being pushed ahead.

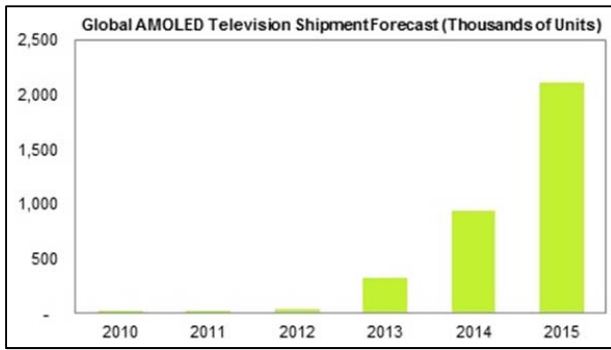

Figure 3

LTPS Technology Advantages

Most LCDs are produced using amorphous silicon thin-film transistors (a-Si TFTs). Although a-Si suffers from poor mobility, it is a low-cost semiconductor material acceptable for many applications. However, as FPD performance has continued to increase over time, the need for higher mobility backplanes has grown. The main reasons for this are to reduce TFT size for super-high resolution small/medium LCDs to increase transmission and battery life as well as to provide sufficient current to drive active-matrix organic light emitting diode (AMOLED) devices (see Fig.4).

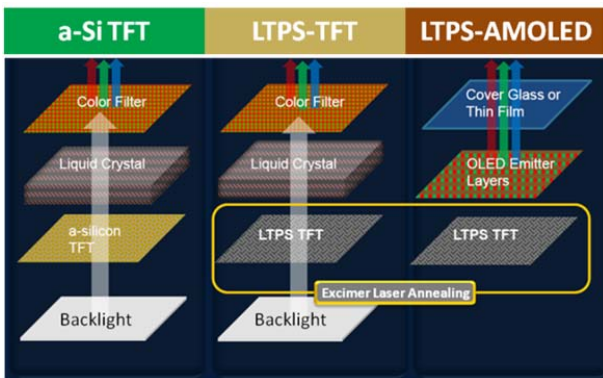

Figure 4

Pixel aperture ratios become larger, producing brighter and lower power displays (see Fig.5). The smaller size and improved performance of polysilicon thin-film transistors (TFTs) also make them suitable for higher-definition display applications.

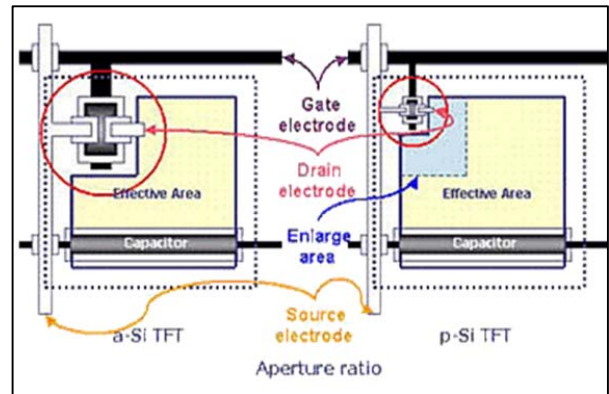

Figure 5

The limits of using amorphous silicon backplanes are probably best visualized in the thermal image comparison of the iPad 2 and the new iPad (iPad 3). When Apple moved from a 1024x768 to a 2048x1536 pixel resolution for the iPad 3's display, it had to more than double the number of LED backlights to account for the loss in effective pixel area, since the TFT transistors made of a-Si could not be made smaller. As a consequence, the battery's capacity had to also be increased significantly with the result of a thicker housing. As shown in figure 6, the iPad 3 runs hotter than its predecessor. Thermal camera evaluations indicate that the back of the iPad 3 becomes 5-8 degrees Celsius warmer than its predecessor.

Thermal comparison of iPad2 and iPad3 both based on a-Si backplanes

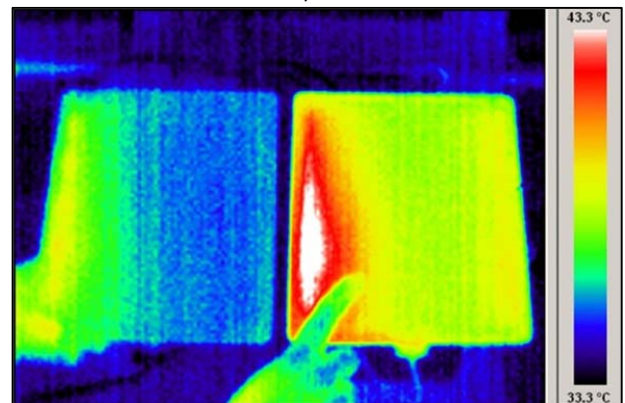

Figure 6

Moreover, better TFT performance may be coupled with lower panel-manufacturing costs. Driver circuitry, which typically accounts for 5-30% of the total panel cost, can be integrated into a polysilicon display. Fabricating the drivers directly on the glass eliminates the traditional tape-automated-bonding driver package,

simplifies the display module process, and slashes module process equipment costs. Integration not only reduces costs, but increases reliability and module process throughput because fewer interconnects are needed. In addition, the large reductions in pixel-charging time allow "point-at-a-time" addressing architectures, which dramatically reduce the number of required driver circuits. The panel controller, memory, and other circuitry can also be integrated onto the panel (see Fig.7). Polysilicon SRAMs and high-voltage circuitry lend themselves to a wide range of integrated "system-on-glass" applications.

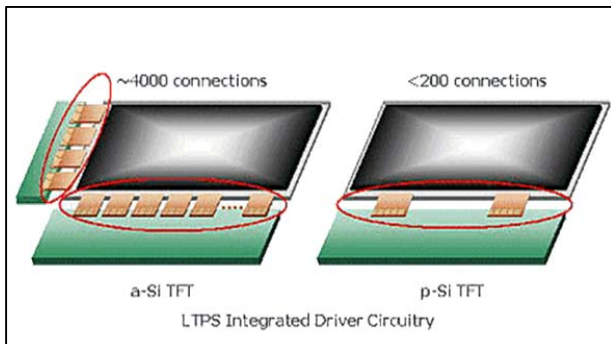

Figure 7

Conventional high-temperature polysilicon processing requires quartz substrates that are too expensive. Consequently, LTPS technology has become the mainstream and is standardly based on excimer laser annealing (ELA). Current 308 nm excimer laser annealing systems have been upscaled to support glass substrates up to Gen 8 panel size.

Excimer Laser Annealing

Excimer Laser Annealing (ELA) is a key process step for converting the amorphous silicon (a-Si) to polycrystalline silicon (p-Si) which provides more than hundred times higher electron mobility. Technically, a 308 nm excimer laser line beam is scanned over a thin (typical 50 nm) a-Si film, which absorbs the UV radiation, partially melts the surface, and leads to the formation of polysilicon (see Fig.8).

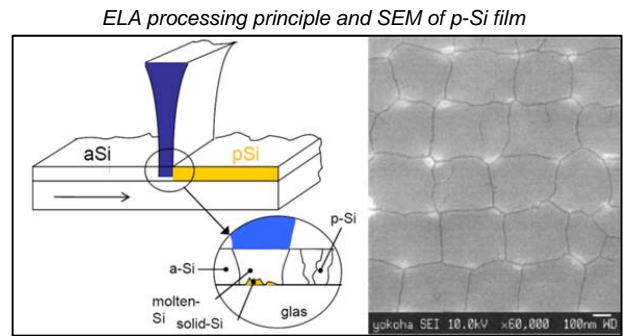

Figure 8

The line beam has a final homogeneity of 1.8% (2σ) to allow 10 to 20 irradiations of each location with the same fluence when scanning the substrate. This can be performed at temperatures as low as 200°C, eliminating the need for expensive glass substrates. The result is a backplane with very homogeneous film of polysilicon of approximately 0.3 μm² x 0.3 μm² grain size providing 100 to 150 cm²/Vs which is two orders of magnitude higher than the electron mobility of an amorphous silicon backplane.

Low-temperature polysilicon (LTPS) fabrication using excimer laser annealing has been in mass production for almost 15 years. In the latest ELA system, state of the art cylindrical optics deliver a homogeneous line beam with dimension 750 mm x 0.4 mm enabling Generations 5.5 to 8 panel annealing (see Fig.9).

Seven inch LTPS displays produced on Gen 5.5 substrate panel (Source: Samsung)



Figure 9

State-of-the-Art ELA System: VYPER/LB750

The latest 308 nm excimer laser model VYPER (see Fig.10) forms the backbone of today's Gen 5.5. to Gen 8 LTPS mass production.

In the novel dual oscillator of the VYPER, 1.2 kW output power was achieved by temporally synchronizing two high power UV-oscillators each capable of 1 Joule energy per pulse and 600 Hz pulse frequency. The dual oscillator excimer laser platform VYPER delivers an exceptional output power stability of 0.45%, rms measured over a gas lifetime of 100 million laser pulses.

1200W 308 nm excimer laser VYPER



Figure 10

In order to fully utilize the UV power, a beam delivery concept has been developed projecting both laser beams of the VYPER laser into a homogeneous line beam of 750 mm length and 0.4 mm width supporting fast polysilicon annealing on large glass substrates and enabling up to four times higher productivity at the flat panel display manufacturing site.

The general layout of the complete excimer laser annealing system consisting of a dual oscillator VYPER laser, the modules for beam forming, homogenizing, mixing and line beam projection and the annealing chamber is shown in figure 11.

Excimer laser annealing system VYPER/LB750

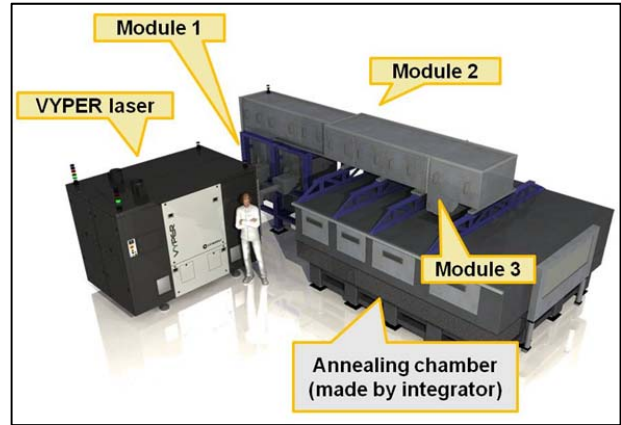

Figure 11

Each oscillator beam enters the beam forming module 1 at a pulse energy of 1 Joule and is spatially formed by a telescope to fit the area of a subsequent homogenizing stage. After beam homogenization the beams are extended and overlaid within module 2. Since overlaying the beams and adding their pulse energy occurs after significant beam extension, the optics of all modules are operated well below their damage threshold. In module 3 the homogeneous line beam is projected into the integrators annealing chamber and absorbed by the amorphous silicon substrate. The processing rate is of the order of 100 cm² per second

Conclusion

Excimer laser fabrication of low-temperature polysilicon (LTPS) has been in mass production for more than 10 years, a technology which is fueling the mobile display revolution. High-resolution LCDs and AMOLEDs are a substantial growth opportunity for LTPS. In 2012, LTPS manufacturing will take off as tier 1 display manufacturers SMD, Sharp, and Toshiba all ramp up new Gen 5.5/6 LTPS fabs, and as SMD begins production on its Gen 8 LTPS pilot line.