

Compact Evolution Series

Industrial High Power Diode Laser

The Compact Evolution series products are high power, fiber-coupled, industrial diode laser systems offering up to 600 W output power. With a modular and robust design, the Compact Evolution provides optimum efficiency, flexibility, and reliability in industrial applications such as plastic welding, selective soldering, brazing and heat treatment.

Compact Evolution series products offer a turn-key solution with an extensive range of accessory options that provide flexibility for integration into a wide range of laser-based manufacturing systems.

FEATURES & BENEFITS

- Output power: up to 600 W
- 19" Rack for easy integrate
- Long life diode modules
- Equipped with control unit for internet-accessible diagnostics and e-service

APPLICATIONS

- Brazing
- Heat Treatment
- Plastics Welding
- Scientific Applications
- Selective Soldering



SPECIFICATIONS		Compact Evolution 980				
Nominal Power (W)		200	300	400	500	600
Power Range (%)		10 to 100				
Laser Beam Quality (BPP) (mm * mrad)		22				
Power Stability Over 24-hour; Cooling Water $\Delta T = \pm 1$ K (%)		± 2				
Pulse Frequency Range	Laser On-Signal (Hz)	1000				
	Analog Modulation (Hz)	600				
Wavelength (nm)		980				
ELECTRICAL RATINGS						
Voltage		200 to 240 (1P//N/PE)				
Connected Load (kVA)		~0.4	~0.6	~0.8	~1.1	~1.3
Effective Power at Nominal Power (kW)		~0.5	~0.7	~0.9	~1.2	~1.4
Max. Current Consumption at 400 V (A)		~2.2	~3	~3.9	~5.2	~6
Fuses Type NH (A)		16				
COOLING						
Recommended Cooling Capacity (kW)		0.25	0.35	0.5	0.6	0.8
Cooling Water* Pressure (Max. Value) (bar)		6				
Cooling Water* Temperature (°C)		22 \pm 1K				
Cooling Water* Flow Rate (Min. Value) (l/min)		3	5	5	10	10
Pressure Drop (hPa)		2000	3500	3500	1000	1000
FIBER DELIVERY SYSTEM						
Interface		QBH				
Diameter (μ m)		200				
Numerical Aperture		0.22				
Length (m)		≤ 20				
Accessories (options)		Fixed Optics, Scanners, Process control via Pyrometer, Chiller				
DIMENSIONS & WEIGHTS						
Laser Dimension (L x W x H) (mm)		~600 x ~483 x ~133				
Laser Weight (kg)		<30				
ENVIRONMENTAL CONDITIONS						
Ambient Temperature in Operation		18 to 40°C (64 to 104°F)				
Storage Temperature		5 to 50°C (41 to 122°F)				
CUSTOMER INTERFACE						
Analog Power (V DC)		0 to 10 (600 Hz ma. Modulation frequency)				
Digital Signals (V DC)		24				
Interface for Control via PC		Ethernet				
OPTIONS LASER						
		Bus Interface (RS232, CanOpen, EtherCAT, RTI, ...)				

* Use water according to DIN ISO 3696

AVAILABLE ACCESSORIES

COLLIMATORS	FIXED OPTICS	FIXED OPTICS WITH INTEGRATED PYROMETER
 <p>The collimator is optimized to the requirements of Compact Series diode laser optical specifications: It is available with different collimating focal length for SMA and QBH fiber connector.</p>	 <p>The processing head with fixed spot size is used for soldering or contour welding. Different focal length allow a wide variation of spot sizes to meet the requirements of the application.</p>	 <p>The processing head with integrated pyrometer is used for non-contact measuring of the work piece temperature and enables closed loop temperature control. A powerful software package allows processes documentation and optimization.</p>
SCANNER OPTICS	SCANNER OPTICS WITH INTEGRATED PYROMETER	OPTICS FOR RADIAL WELDING
 <p>Scanner optics is used for quasi-simultaneous welding. A broad variation of spot sizes and scanning fields are available to meet the requirements of the application.</p>	 <p>The processing head enables quasi-simultaneous welding with the advantage of closed loop temperature control.</p>	 <p>The processing head enables simultaneous welding of a radial symmetrical component without rotating part or optics. Customer specific, dimensioning and optical set up can be optimized to the welding geometry.</p>
OPTICS FOR RADIAL WELDING WITH INTEGRATED PYROMETER	LINE OPTICS	INTERFACE CONVERTER
 <p>The processing head enables quasi-simultaneous welding of a radial symmetrical component with the advantage of closed loop temperature control. The programmable servomotor allows the welding without rotating the part.</p>	 <p>Line optics are used for applications that require a rectangular or square spot. Customized optical layouts allow a wide variation of different foci's.</p>	 <p>Interface Converter allows customers already using Compact Lasers an easy upgrade to Compact Evolution without changing the wiring of the customer interface.</p>

All processing heads are available with SMA or QBH fiber connector.

MECHANICAL SPECIFICATIONS

Compact Evolution Series

Front View

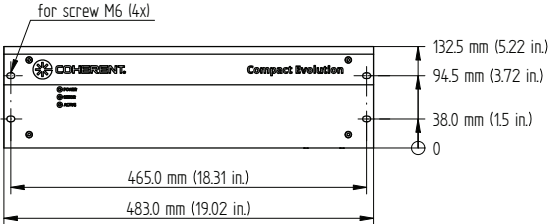

Side View

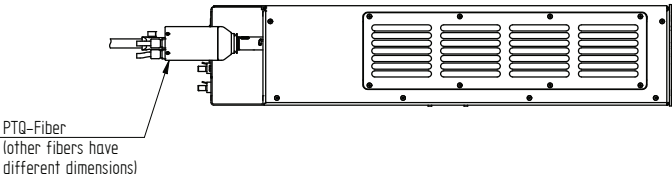

Top View

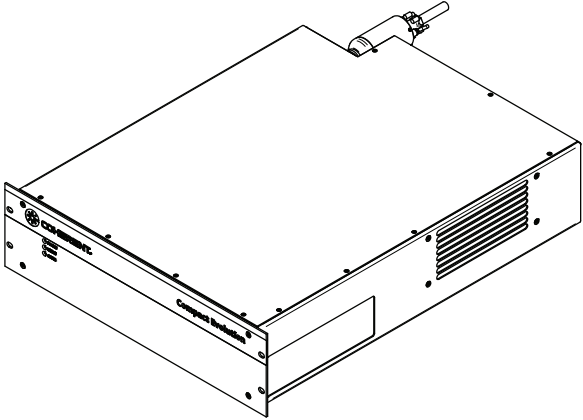
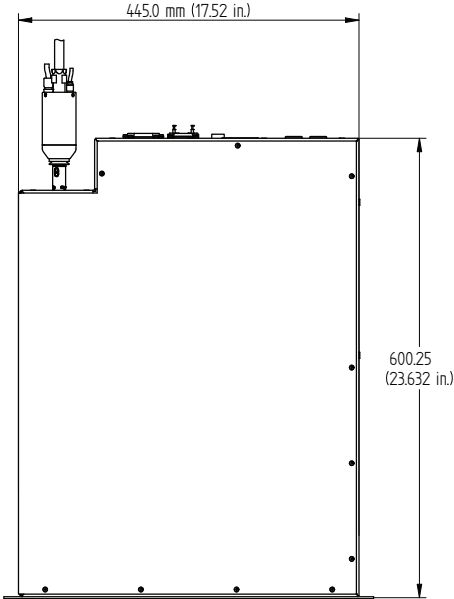

Industriegehäuse 19"-3HE
Industrial Rack Mount 19"-3HU
Rack Industriel 19"-3UH



Coherent, Inc.,
5100 Patrick Henry Drive Santa Clara, CA 95054
p. (800) 527-3786 | (408) 764-4983
f. (408) 764-4646

tech.sales@coherent.com www.coherent.com

Coherent follows a policy of continuous product improvement. Specifications are subject to change without notice. Coherent's scientific and industrial lasers are certified to comply with the Federal Regulations (21 CFR Subchapter J) as administered by the Center for Devices and Radiological Health on all systems ordered for shipment after August 2, 1976.

Coherent offers a limited warranty for all Diode Laser Systems. For full details of this warranty coverage, please refer to the Service section at www.coherent.com or contact your local Sales or Service Representative. MC-006-19-0M0519. Copyright ©2019 Coherent, Inc.

