



HighLight 1000F

Direct-Diode Industrial System



Features

- 1000 Watts of diode laser power
- Fiber delivery - 600 μm fiber core
- Supports welding, cladding and heat treating
- Up to 30% efficiency
- Laser on/off; no simmer required
- Suitable for industrial environments
- 635 nm Alignment Laser Standard
- Reliable and robust

Mechanical Specifications

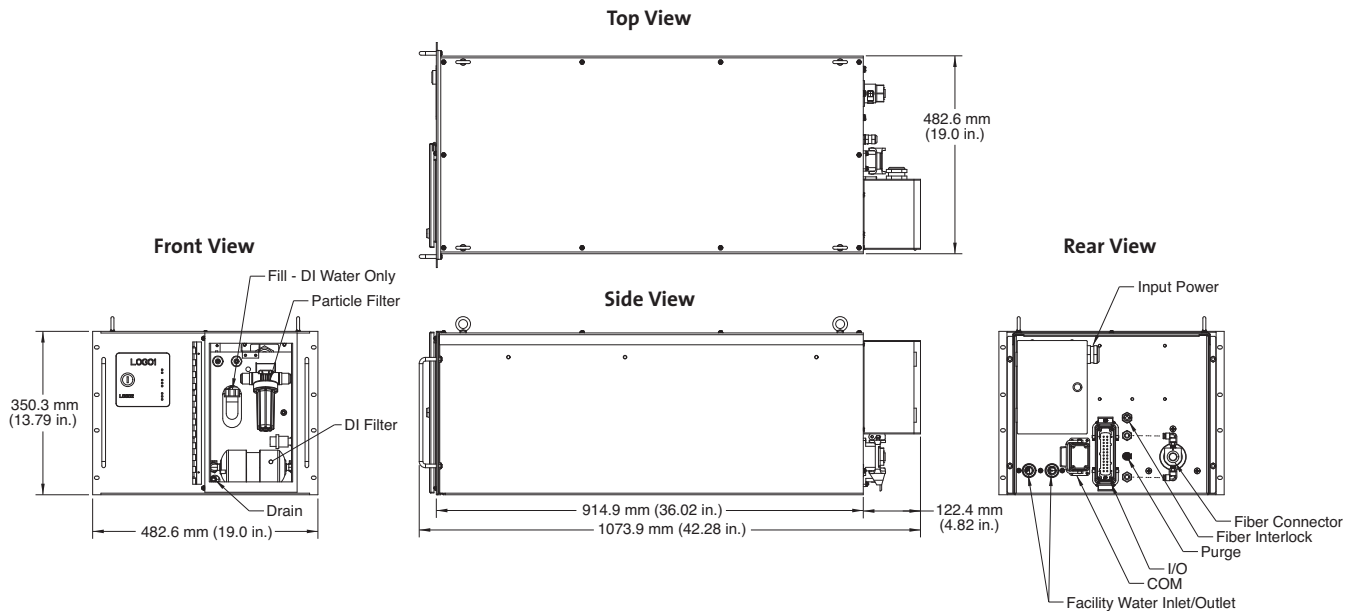

Superior Reliability & Performance

HighLight™ 1000F

Direct-Diode Industrial System

System Specifications	Output Power (W)	1000
	Power Stability ¹ (%)	±2
	Wavelength (nm)	975 ±10
	Fiber Length (m)	10 or 50
	Fiber Core Diameter (µm)	600
	Fiber NA ²	0.2
Mechanical Specifications	Weight	~90 kg (198.4 lbs.)
	Dimensions (L x W x H)	1074 x 483 x 351 mm (42.3 x 19.0 x 13.8 in.)
Control Specifications	Analog Input (V)	0 to 10
	Ready, Enable (V)	24 (digital)
	Interlocks	Yes
Facilities Requirements	Electrical	
	Operating Voltage (VAC)	230, single phase
	Frequency (Hz)	50/60
	Max Current Draw (A)	20
	Load (kW)	≤4.1
	Cooling Water	
	Flow Rate (l/min.)	15 to 20
Temperature	15 to 18°C (59 to 64.4°F)	
Environmental Conditions	Purge	
	Medium	Grade D breathing air
	Pressure (psi)	10 to 15
Environmental Conditions	Operating Temperature	15 to 35°C (59 to 95°F)
	Storage Temperature	5 to 65°C (41 to 149°F)
	Operating Humidity (%)	10 to 80 non-condensing

¹ At full power after one-minute warm-up.
² Based on half angle.

HighLight 1000F PIV Curve

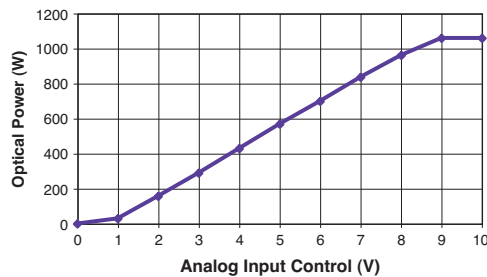

Coherent follows a policy of continuous product improvement. Specifications are subject to change without notice.

Coherent's scientific and industrial lasers are certified to comply with the Federal Regulations (21 CFR Subchapter J) as administered by the Center for Devices and Radiological Health on all systems ordered for shipment after August 2, 1976.

Coherent offers a limited warranty for all HighLight Systems. For full details of this warranty coverage, please refer to the Service section at www.Coherent.com or contact your local Sales or Service Representative.



www.Coherent.com

Coherent, Inc.
 5100 Patrick Henry Drive
 Santa Clara, CA 95054
 phone (800) 527-3786
 (408) 764-4983
 fax (800) 362-1170
 (408) 988-6838
 e-mail tech.sales@Coherent.com

Benelux +31 (30) 280 6060
 China +86 (10) 6280 0209
 France +33 (0)1 6985 5145
 Germany +49 (6071) 968 333
 Italy +39 (02) 34 530 214
 Japan +81 (3) 5635 8700
 Korea +82 (2) 460 7900
 UK +44 (1353) 658 833

